

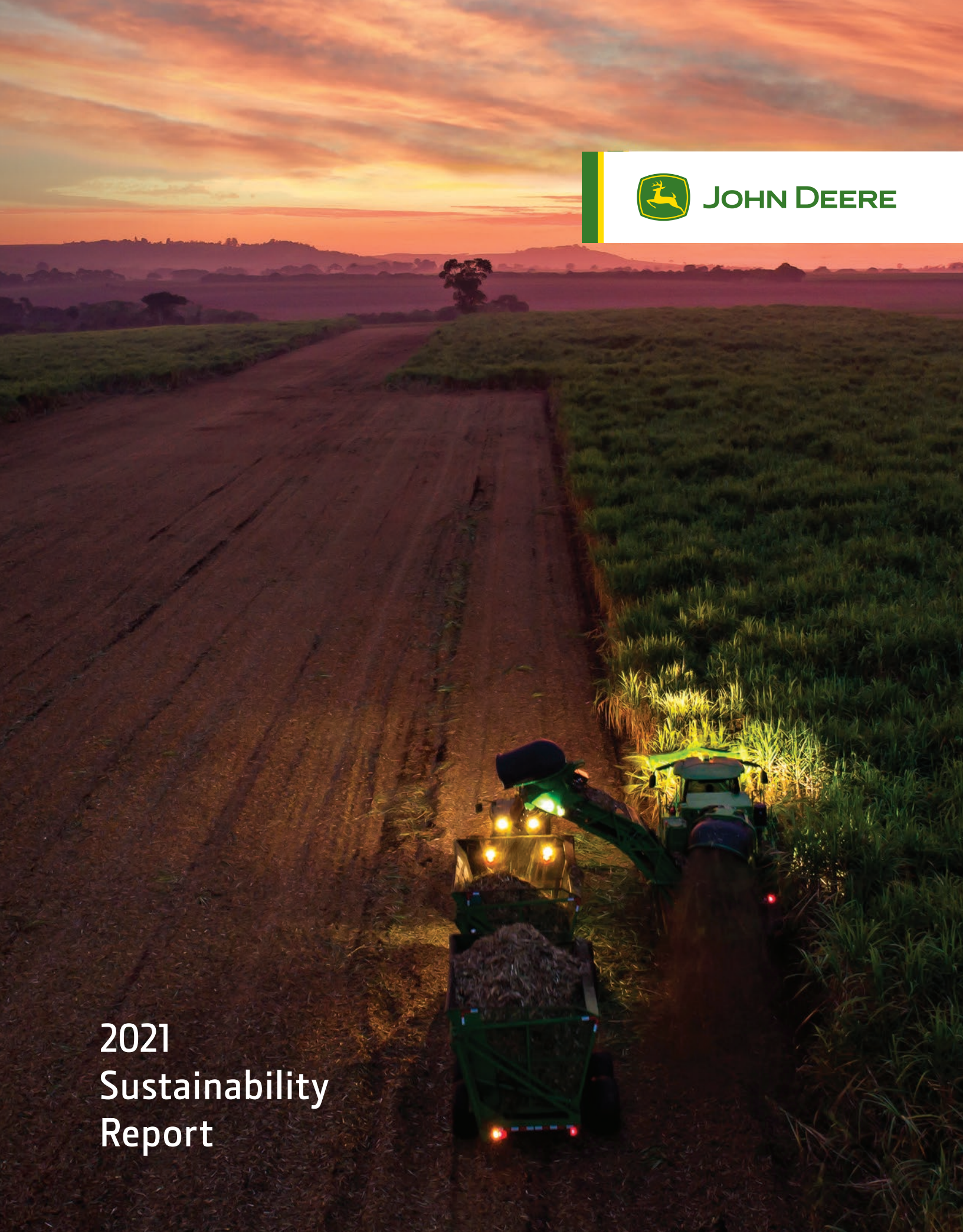

**JOHN DEERE**

**2021  
Sustainability  
Report**

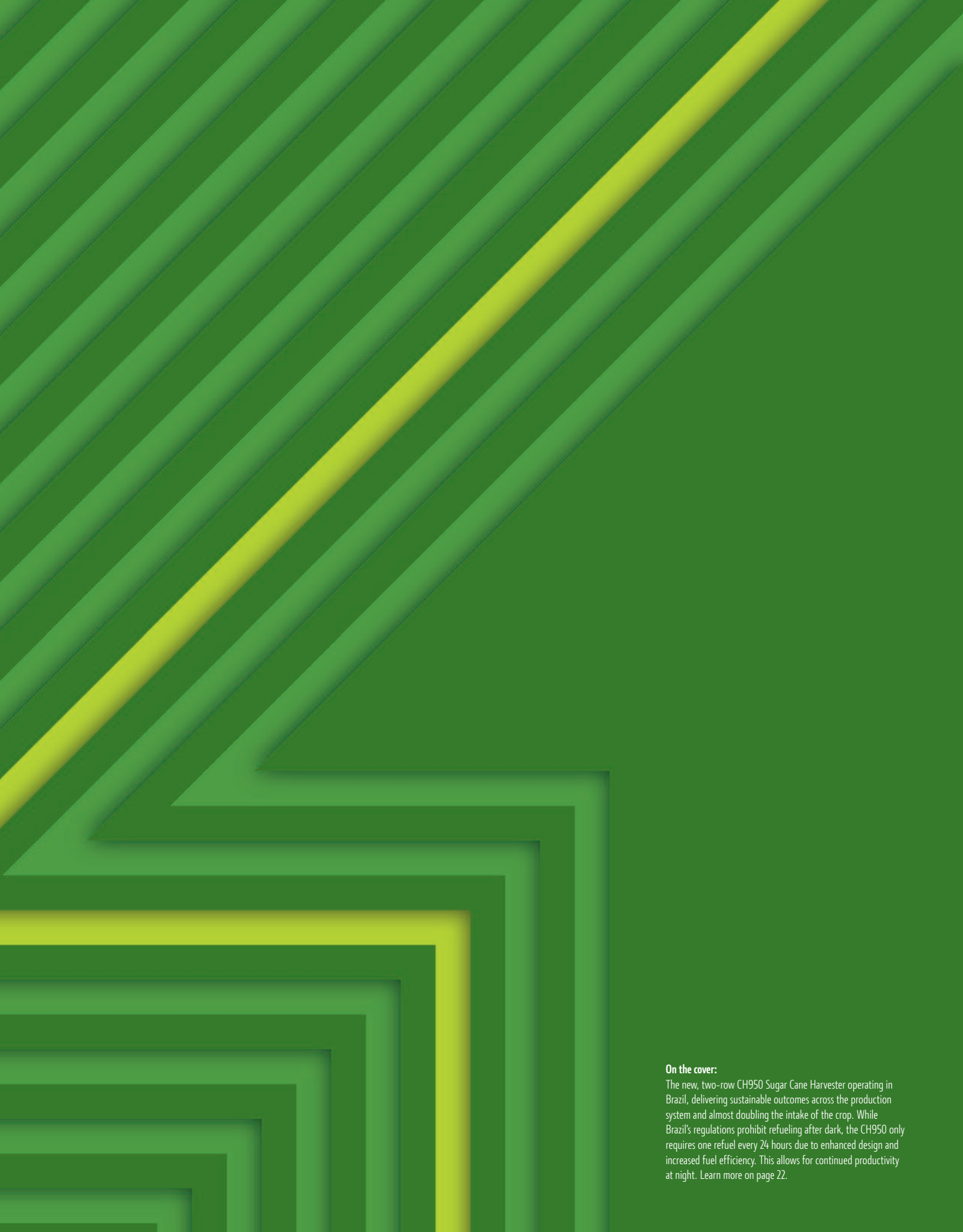



**On the cover:**

The new, two-row CH950 Sugar Cane Harvester operating in Brazil, delivering sustainable outcomes across the production system and almost doubling the intake of the crop. While Brazil's regulations prohibit refueling after dark, the CH950 only requires one refuel every 24 hours due to enhanced design and increased fuel efficiency. This allows for continued productivity at night. Learn more on page 22.

The background features a series of parallel, diagonal lines in various shades of green, with one prominent line in a bright yellow-green. In the bottom right corner, there is a series of concentric, stepped rectangular shapes, also in shades of green and yellow-green, creating a sense of depth and movement.

We run so  
life can *leap*  
*forward.*



Page 6  
Chairman and  
CEO Letter



Pages 12–29  
Our Strategy  
in Action

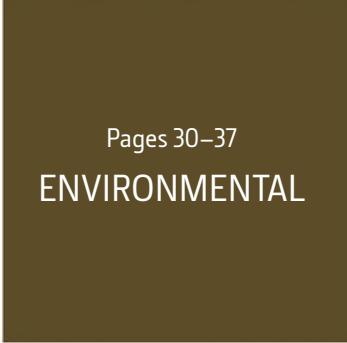

Pages 30–37  
ENVIRONMENTAL

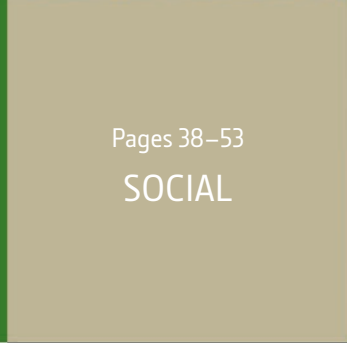

Pages 38–53  
SOCIAL



- 5 2021 Highlights
- 6 Chairman and CEO Letter
- 8 Sustainability Priorities Informed by Materiality Assessment
- 10 Our Next Leap



Pages 54–62  
GOVERNANCE

## OUR STRATEGY IN ACTION

- 13 Progress Toward Our Goals
- 14 Data and Technology Demystify Cotton Production
- 17 Turning Data Into Value
- 18 Connected Machines Support Sustainable Forest Management
- 22 CH950 Boosts Efficiency, Sustainability of Sugar Cane Harvest
- 26 See & Spray™ Select: Saves (and Targets) Green
- 28 An Opportunity the Size of the Fleet: Performance Upgrades Promote Sustainability

## ENVIRONMENTAL

- 31 Climate Stewardship
- 32 Energy and Emissions
- 35 Product Circularity
- 37 Responsible Water Use
- 37 Waste Elimination

## SOCIAL

- 39 DEI Framework
- 40 Leading With a DEI Mindset
- 44 Prioritizing Our People
- 47 Dealership Talent
- 48 The John Deere Foundation's Bold Commitment
- 51 Workplace Health and Safety
- 52 Product Quality
- 53 Product Safety

## GOVERNANCE

- 55 Corporate Governance
- 56 Sustainability Governance
- 58 Cybersecurity and Data Privacy
- 59 Supply Chain Management
- 60 Compliance
- 61 Human Rights
- 62 Political Engagement

- 64 Data Tables
- 66 Awards

2021 HIGHLIGHTS

Net Sales & Revenues

\$44.024B

Shareholder Value Added

\$5.128B



315M+ Engaged Acres

Total Connected Machines

(Ag & Construction)

440,000+



Increase of Women in Global Management Positions from 2020

More females overall in the workforce



Increase of Non-White Employees in U.S. Management from 2020

27.8M+

Pounds of Material Recycled Through Remanufacturing

Sustainable Innovations Launched

See & Spray™ Select System

Integrated ExactRate™ Liquid Fertilizer Solution

CH950 Sugar Cane Harvester

C770 Cotton Harvester



\$42.5M Community Investment



20%

Scope 1 & 2

Greenhouse gas emissions reduction achieved since 2017



4%

Scope 1 & 2

Greenhouse gas emissions reduction achieved in 2021

JOHN C. MAY  
CHAIRMAN AND CEO



CHAIRMAN AND CEO LETTER

# A year ago we were reminded that people are at the center of our purpose: We run so life can *leap forward*.

Our people have led our business strategy, helped us overcome numerous challenges caused by COVID-19, and stepped forward in our communities. They have stood tall, moved forward, and asked, “What’s next?”

Their efforts are evident in all the successes we celebrate.

This path to success is paved by the company’s Smart Industrial strategy and the sustainable outcomes our integrated technology stack provides. Our customers — and key stakeholders — benefit by becoming more productive, profitable, and mindful of their impact on the world around them.

Initiatives like our new excavator strategy and acquisitions like Bear Flag Robotics carry this mission forward and accelerate our transformation from automation to autonomy. This evolution includes “sense-and-act” technologies that enable more precise, more productive, and more sustainable outcomes.

We are also utilizing data like never before, linking behaviors to solutions such as the John Deere Operations Center which includes more than 315 million engaged acres worldwide. That connection is at the heart of our equipment — making it run more efficiently while providing real-time insights and putting us closer to our customers and their changing businesses.

To those working in cotton and sugar cane fields around the world, we have listened, applying technology to make the complex more manageable. And we have gone into forests with loggers and made maintaining and harvesting that unique crop safer, smarter, and more sustainable.

It is our people who will use their unique expertise, insight, and commitment to pursue our 2022 Sustainability Goals. And we continue to recruit, develop, retain, and promote a diverse workforce, shaped by an understanding that our solutions are better when many voices are heard. We value that view, believing ideas must come from a variety of lived experiences, strengthening us as a whole.

Finally, in reaching a new labor agreement we continued to invest in our people, bringing security, certainty, and continuity to our production and maintenance workforce — all while ensuring our business remains competitive.

Our Smart Industrial business model has made us more agile and direct, strengthening how we lead by example — whether it’s through a weeklong hackathon; an inspiring Diversity, Equity, and Inclusion framework; or navigating a pandemic and strained supply chain. It is here where our people shine.

John Deere is often gauged by the products we provide — and make no mistake, our products are second to none. However, we realize the world’s many challenges cannot be solved by equipment alone. Challenges like a deteriorating infrastructure, climate change, and social inequality push us to think beyond today. Answers will come from our grit, determination, and collaboration.

In our neighborhoods and villages — where food security, housing, and education must be elevated — we have made a commitment to future generations by investing at least \$200 million over the next 10 years, pledging bold support in places both familiar and far away.

And while what is highlighted in this Sustainability Report shows what a unified company can accomplish, it does not measure all that we can become. Together, we have identified a new direction for what comes next as outlined in our Leap Ambitions, which aligns our new business goals with new sustainability goals. By executing our strategy in pursuit of better outcomes — using fewer resources — we will drive change on a global scale.

It is in that horizon where I see life leaping forward and society thriving. It is why we run.



Chairman and CEO

# SUSTAINABILITY PRIORITIES INFORMED BY MATERIALITY ASSESSMENT

In 2021, John Deere completed our inaugural sustainability materiality assessment to identify, assess, and prioritize the sustainability topics most significant to our business and our stakeholders. In working with a third-party firm on our most significant environmental, social, and governance (ESG) topics based on the Global Reporting Initiative (GRI) Standards, John Deere sought to understand our greatest ESG impacts, opportunities, and risks, and the influence of these on our stakeholders' decision making.

Members of our executive team were engaged to identify a cross section of stakeholders. Participants included John Deere leaders, customers, investors, dealers, suppliers, government agencies, industry associations, non-governmental organizations (NGOs), academia, and the general public. We engaged each of these groups to discuss areas of interest and perceived impact, risks, and opportunities associated with John Deere's material ESG topics.

The results of the materiality assessment informed our approach to reporting, and also served as a framework for evaluating and planning our future sustainability goals and objectives. The key topics for our business from an ESG perspective are reflected on the right.

We believe continuous engagement with our stakeholders is integral to achieving our higher purpose and is part of the foundation on which we build trust and hold ourselves accountable to our stakeholders. Therefore, we continue to engage regularly with our diverse stakeholder groups, including customers, dealers, employees, investors, and community leaders. This continuous engagement is used alongside our materiality assessment as another input for assessing and prioritizing our sustainability priorities.

For example, to ensure the continued delivery of sustainable, long-term value to our shareholders, we engage in proactive shareholder outreach three times per year, in addition to our regular ongoing dialogue with shareholders and potential shareholders throughout the year. These proactive outreach efforts focus on governance, executive compensation, sustainability, and other ESG topics. During 2021, we invited shareholders representing more than 45 percent of outstanding share ownership to engage in conversations with us on these topics. Of those we contacted, shareholders representing over 40 percent of outstanding share ownership participated in meetings and offered valuable insights.

## HIGHEST-PRIORITY TOPICS

### ENVIRONMENTAL

- Climate Stewardship
- Emissions & Energy
- Harmful & Hazardous Chemicals & Substances
- Land, Habitat, & Forest Conservation
- Recyclability & Product Lifecycle Impacts
- Soil Health
- Sustainable Food & Agriculture
- Waste
- Water Quality & Availability

### SOCIAL

- Diversity, Equity, & Inclusion
- Employee Health, Safety & Wellness

### GOVERNANCE

- New Technologies & Innovations
- Urbanization & Sustainable Infrastructure

## TOPICS FOR ACTIVE MANAGEMENT AND MONITORING

### SOCIAL

- Dealership Talent
- Product Quality, Durability & Reliability
- Product Safety & Health
- Talent Attraction, Engagement & Retention
- Traceability, Nutrition, & Sustainable Diets
- User/Customer Experience & Satisfaction

### GOVERNANCE

- Data Privacy & Product Security
- Geopolitical Events
- Human Rights & Labor Relations
- Intellectual Property (IP)
- Market Access & Trade Barriers
- Political Participation & Advocacy
- Responsible Supply Base & Sourcing



In response to the feedback received from shareholders during 2021, some of the actions we have taken include:

- Quantified our Scope 3 greenhouse gas emissions and included in this report
- Analyzed our risks and opportunities related to climate change to include a Task Force on Climate-related Financial Disclosures Report with this report
- Evaluated and set Science Based Target commitments for our Scope 1, 2, and 3 greenhouse gas emissions
- Further expanded customer outcome-focused disclosures in this report and launched new Leap Ambitions to further demonstrate alignment of strategy and sustainable outcomes
- Included this key topic summary to serve as a guide for our sustainability priorities and strategy
- Published [EEO-1 Disclosure](#) (with respect to our U.S. employees)

Multiple sustainability frameworks also impact our sustainability priorities and reporting. Our approach to sustainability reporting is aligned with our internal Enterprise Risk Management process. We also continue to align our reporting with the material issues identified by the [Sustainability Accounting Standards Board \(SASB\)](#), including those specific to the Industrial Goods and Machinery industry. Our 2021 report continues to incorporate [Global Reporting Initiative \(GRI\)](#) reporting and support of the [United Nations Sustainable Development Goals \(UN SDGs\)](#). Given the increasing importance and potential impact of climate change on our business and our world, John Deere also is reporting in alignment with the [Task Force on Climate-related Financial Disclosures \(TCFD\) Report](#) for the first time this year and will continue to report to CDP on an annual basis.

## 2021 Shareholder Engagement Summary



**JOHN DEERE** is uniquely positioned to deliver both **ECONOMIC** and **SUSTAINABLE VALUE** for our customers through **ADVANCED TECHNOLOGY** and **SOLUTIONS**.

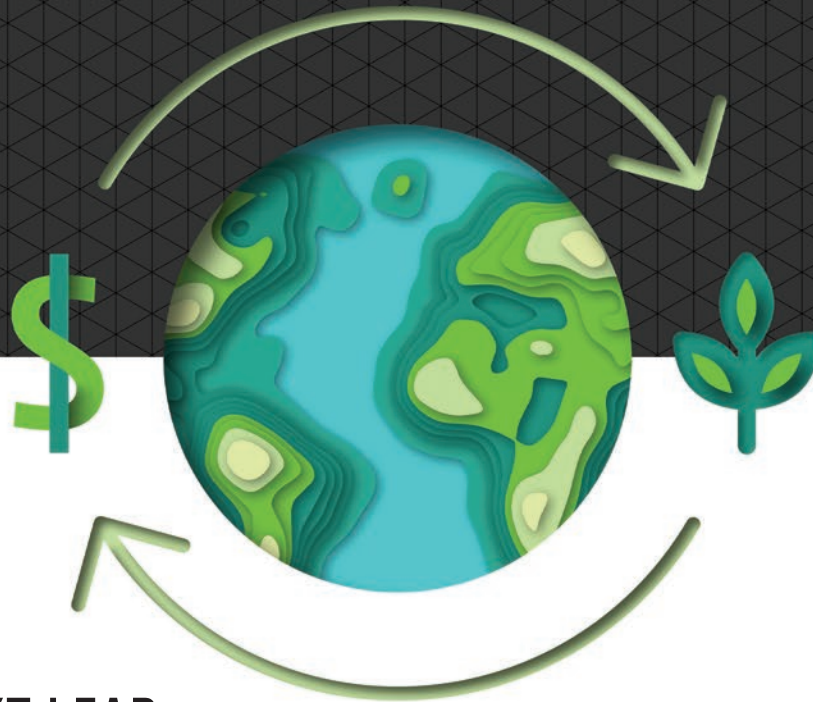

## OUR NEXT LEAP

In 2020, we announced a new vision and operating model to accelerate success through the integration of smart technology innovation with Deere's legacy of manufacturing excellence.

The Deere Smart Industrial strategy focuses on delivering intelligent, connected machines and applications that will revolutionize production systems in agriculture and construction, unlocking customer economic value across the lifecycle in ways that are more sustainable for all.

The core elements of our strategy's operating model — Production Systems, Technology Stack, and Lifecycle Solutions — paired with a new approach to capital allocation and the best team in the industry, are enabling us to innovate with agility and speed.

Our customers face increasing challenges that make their businesses more competitive and dynamic. We will build

on our track record by creating and delivering customer value through technological innovation, engineering and manufacturing excellence, and a world-class dealer channel, all of which uniquely position Deere to anticipate, address, and outpace these challenges better than anyone.

We're pleased to announce our Leap Ambitions — the measures of our strategy. Our ambitions align across our customers' production systems to optimize their complete operations — ensuring that every hour, every drop, every seed, every pound, and every pass counts — delivering better outcomes with fewer resources.

Our Leap Ambitions are focused goals designed to boost economic value and sustainability for our customers. We've committed to achieving these goals within four-year (2026) and eight-year (2030) periods. These Leap Ambitions mean great things for our customers, employees, investors, dealers, suppliers, and others who have a stake in John Deere.

# INCREMENTAL ADDRESSABLE MARKET OPPORTUNITY

# > \$150 BILLION

## EXECUTING OUR STRATEGY



### PRODUCTION & PRECISION AG

#### By 2026

- Reach 500 million engaged acres\* with 50% highly engaged\*\*

#### By 2030

- Ensure 75% of engaged acres are sustainably engaged\*\*\*



### SMALL AG & TURF

#### By 2026

- Ensure 100% of new Small Ag equipment is connectivity enabled
- Offer an electric option in each Turf and Compact Utility Tractor product family
- Deliver a fully autonomous, battery-powered electric ag tractor to the market

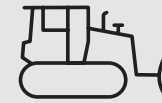

### CONSTRUCTION & FORESTRY

#### By 2026

- Deliver 20+ electric and hybrid-electric product models
- Earthmoving: Increase SmartGrade™ grade control adoption to 50%
- Forestry: Boost Intelligent Boom Control adoption to 100%
- Roadbuilding: Increase Precision Roadbuilding Solutions adoption to 85%

**DELIVER ONGOING VALUE TO CUSTOMERS IN ALL THREE BUSINESS SEGMENTS**

Connect **1.5 million** machines by 2026

Demonstrate viable low/no carbon alternative power solutions by 2026

Grow enterprise **recurring revenue to 10%** by 2030

## FINANCIAL AND SUSTAINABLE OUTCOMES

### Equipment Operations OROS at 20% by 2030



#### Enhance Ag Customer Outcomes by 2030

- Improve nitrogen use efficiency 20%†
- Increase crop protection efficiency 20%†
- Reduce 15% of customer CO<sub>2</sub>e emissions†



#### Product Circularity by 2030

- Achieve 95% recyclable product content
- Ensure 65% of product content is sustainable material
- Grow 50% in remanufacturing revenue



#### Safety by 2026

- Improve Total Recordable Incident Rate 20%



#### Reduce Environmental Footprint by 2030

- 50% of operational CO<sub>2</sub>e emissions (Scope 1 & 2)
- 30% of upstream and downstream CO<sub>2</sub>e emissions (Scope 3)
- 15% of waste intensity
- 10% freshwater consumption intensity at water-stressed manufacturing locations

\* Engaged acres is one of the foundational measures of customers' use of the John Deere Operations Center (our online farm management system). It reflects the number of unique acres with at least one operation pass documented in the Operations Center in the past 12 months.

\*\* Highly Engaged Acres include documentation of multiple production steps and the use of digital tools to complete multiple, value creating activities over a 12-month period.

\*\*\* Sustainably engaged acres include incorporation of two or more sustainable John Deere technology solutions or sustainable practices over a 12-month period.

†Per unit of output



**OUR STRATEGY  
IN ACTION**

# PROGRESS TOWARD OUR GOALS

As we head into the final year of our 2022 Sustainability Goals, we are committed to continuing to strive to achieve these goals. Reflected here is our progress through fiscal year 2021, and we will provide the final outcomes for these goals in our next round of sustainability reporting.

As we look to the future, we have considered the significant progress that our teams have made on this goal suite, and we have set the bar even higher for ourselves with the launch of our new Leap Ambitions. Our Leap Ambitions include

goals that continue to focus on reducing the environmental impact of our own operations and our products, as well as providing a safe and healthy workplace for our world-class employees. We have also broadened the scope of these goals to include a focus on the environmental impact of our complete value chain by integrating a Scope 3 greenhouse gas reduction goal, as well as a new focus on delivering more sustainable outcomes for our customers. Taken together, our Leap Ambitions demonstrate the impressive impact of our strategy in action.



## SUSTAINABLE ENERGY USE<sup>1</sup>

Reduce greenhouse gas emissions by 15% through 50% renewable-energy supply and excellence in energy efficiency.

### GREENHOUSE GAS EMISSIONS (mtCO<sub>2</sub>e)

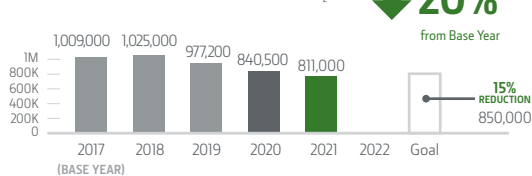

### RENEWABLE ELECTRICITY

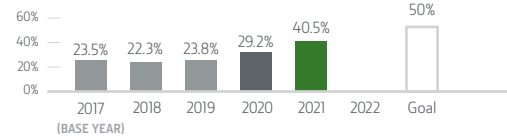

## OCCUPATIONAL HEALTH AND SAFETY<sup>2</sup>

Achieve safety excellence through increased focus on leading indicators, risk reduction, health- and safety-management systems, and prevention.

### ENTERPRISE TOTAL RECORDABLE INCIDENT RATE

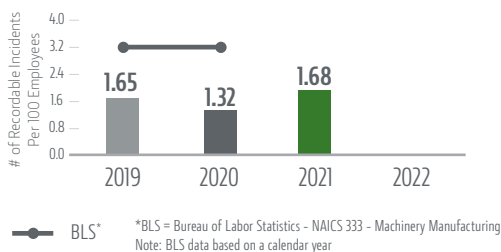

## INCREASE RECYCLING<sup>2</sup>

Recycle 85% of total waste.

### WASTE RECYCLED

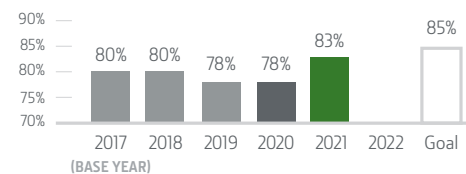

## USE WATER RESPONSIBLY<sup>2</sup>

Implement water best management practices (BMP) in 100% of water-scarce manufacturing locations.

### WATER BMP IMPLEMENTED

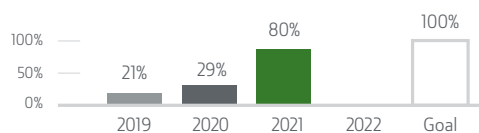

## PRODUCT SUSTAINABILITY<sup>2</sup>

Reduce environmental impact, including CO<sub>2</sub>e emissions, on 90% of new products. Increase the use of sustainable materials by growing remanufactured and rebuild sales by 30% and by increasing recyclable, renewable, and recycled content.

### NEW PRODUCT PROGRAMS WITH LOWER ENVIRONMENTAL IMPACT

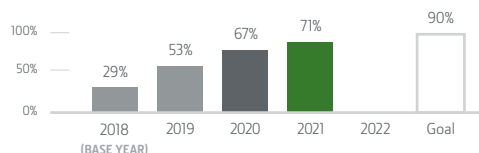

### REMANUFACTURED AND REBUILD SALES GROWTH

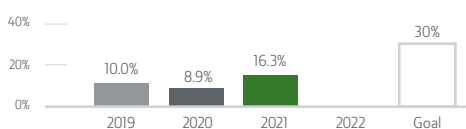

<sup>1</sup>Data associated with the operation of PLA Holding Netherlands B.V., Mazzotti S.r.l., and King Agro Europa, S.L., and their related subsidiaries, and the Wirtgen Group entities are included for all years in the reported metrics. Data associated with the operation of Unimil is not included in the reported greenhouse-gas and renewable-electricity metrics.

<sup>2</sup>Data associated with the operation of PLA Holding Netherlands B.V., Mazzotti S.r.l., King Agro Europa, S.L., and Unimil, and their related subsidiaries, and the Wirtgen Group entities, are not included in the reported waste recycling, water BMP, product sustainability, remanufacturing revenue, and total recordable incident rate metrics.

# DATA AND TECHNOLOGY DEMYSTIFY COTTON PRODUCTION

It's been said that what you can measure you can change. Perhaps there's no better place to test that theory than in a cotton field.

Managing the cotton-growing cycle is so complex that the industry uses an analogy: While growing certain crops is more like doing algebra, growing cotton is like doing calculus. In addition, cotton producers serve an extremely diverse customer base which often desires visibility into the production system in service of sustainability goals.

"The world needs cotton, but perhaps the world doesn't necessarily appreciate what it takes to grow and harvest it," said Steve Young, cotton production system manager at John Deere.

While cotton producers are working through those equations, John Deere is providing technology, best-in-class equipment, and data tools that enable the sustainable outcomes growers and their customers desire.

## THE CALCULUS OF GROWING COTTON

When a cotton plant emerges, it starts growing bolls close to the stalk. Every day or two, another new boll emerges and it becomes a bigger and bigger plant. However, if the plant grows too tall and wide, it won't produce a meaningful cotton crop. Therefore, a grower must constantly manage its growth pattern.

To effectively "manage" a cotton field, growers must apply nutrients and chemicals throughout the growing season including herbicides, plant-growth regulators, insecticides, and fertilizers. In total, a typical growing season involves 11 nutrient and chemical passes per field, which is both expensive and environmentally impactful.





This is where John Deere See & Spray™ system comes in. John Deere's upcoming in-season version of See & Spray can significantly reduce the amount of contact herbicides applied in cotton production using targeted spraying.<sup>1</sup> Deere sees this as just the beginning of the journey to develop "sense-and-act" technology in the field. While four passes in a cotton-growing season involve herbicides, there is tremendous opportunity for future technology to deliver sustainable and economic outcomes that address the remaining seven passes.

Deere's current technology stack is already saving cotton producers an estimated nearly \$50 an acre through innovations like ExactApply™ sprayer system, section control, and AutoTrac™ guidance.<sup>2</sup> With the addition of See & Spray Ultimate system, and its targeted broadcast-spray technology, this figure could climb even higher. Contact herbicides — those that are applied directly to the plants — represent a significant expense item on a grower's financials, costing nearly \$50 per acre.<sup>3</sup> John Deere's in-season See & Spray technology is expected to provide savings of this line item of more than two-thirds, resulting in additional per-acre savings of over \$30.<sup>1,3</sup> This is good for our growers' businesses, and good for the environment.

<sup>1</sup> Results based on internal John Deere strip trials in corn, soybeans, and cotton in Iowa, Mississippi, Texas, and Illinois, in typical growing conditions, with varying weed size, crop canopy, and field conditions, using targeted spray of non-residual herbicide only, and using current software/algorithm at time of trials. Results will vary based on crop and weed pressure.

<sup>2</sup> Based on a model farm growing 3,000 acres of cotton. Values are based on three-year historical average input prices as published by Mississippi State University. Results based on benefits assessed pursuant to third-party studies as well as results of actual customer experience. Results will vary.

<sup>3</sup> Values are based on three-year historical average input prices as published by Mississippi State University.

At the same time, John Deere continues to deliver better and more efficient machine forms to meet customer needs and reduce greenhouse gas emissions. In 2021, John Deere launched the C770 Cotton Harvesters, which are the culmination of more than a decade-long journey that started in 2009 to revolutionize cotton harvesting. These machines represent the most significant advancement in cotton harvesting since going from hand picking to mechanization.

The benefits of the C770 include an impressive 20-percent fuel savings through efficient engine technology and machine design — reducing fuel costs for the customer and lowering greenhouse gas emissions for the environment — and a completely redesigned baler system. During the cotton-harvesting process, each bale is wrapped in plastic to enable transport. The C770 packs more cotton into each bale, and reduces the amount of wrap required per pound by eight percent on cotton pickers and 12 percent on cotton strippers.<sup>4</sup>

More cotton per bale also means more cotton per load hauled to production sites — called gins — where cotton fibers are separated from their seeds. That translates into fewer trips from field to gin, additional fuel and time savings, and an extension of safety beyond the farm by reducing traffic on rural roadways.

<sup>4</sup> Compared to John Deere 7760.

<sup>5</sup> Values are based on three-year historical average input prices as published by Mississippi State University. Results based on benefits assessed pursuant to third-party studies as well as results of actual customer experience. Results will vary.

<sup>6</sup> Annual savings of a model cotton operation of 3,000 acres. Results will vary.

<sup>7</sup> Equivalencies based on U.S. Environmental Protection Agency Greenhouse Gas Equivalencies Calculator, <https://www.epa.gov/energy/greenhouse-gas-equivalencies-calculator>.

## JOHN DEERE'S SUSTAINABLE IMPACT BY THE NUMBERS

Sustainable outcomes delivered annually by John Deere technology on a 3,000-acre model U.S. cotton farm<sup>6</sup>

### \$50 / ACRE

Saved with Deere technology (ExactApply™ sprayer system, section control, and AutoTrac™ assisted steering system), by reducing inputs and improving yield by delivering the annual total farm savings of the following inputs:

- 30 bags of seed
- 260 gallons of defoliant
- 278 gallons of growth regulator
- 692 gallons of insecticide
- 1,329 gallons of fuel
- 1,402 gallons of contact and residual herbicides
- 6,489 gallons of nitrogen fertilizer
- 45,000 pounds of potassium fertilizer

### SEE & SPRAY™ ULTIMATE SYSTEM

Will address contact herbicides, which represent an annual expense for growers of nearly \$50 per acre, and is expected to reduce the amount applied by more than two-thirds, which means an additional savings of over \$30 per acre and more than 2,300 gallons of contact herbicides per year

### C770 HARVESTER IMPACT<sup>5</sup>

- 4,500,000 pounds of cotton harvested
- 1,942 pounds of plastic wrap savings
- 2,995 gallons of fuel savings

In total  
**489 metric tons CO<sub>2</sub>e emissions reduced per year**

Equivalent of **1.2M** passenger vehicle miles driven  
OR **6.5** tanker trucks of gasoline<sup>7</sup>

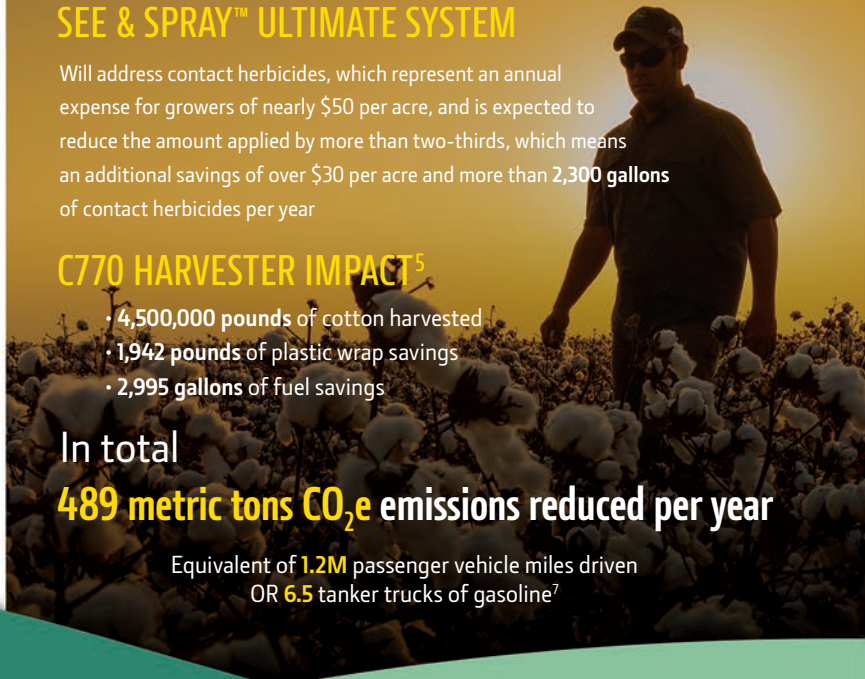

**11** application passes per growing cycle represent 11 opportunities for John Deere technology to optimize inputs

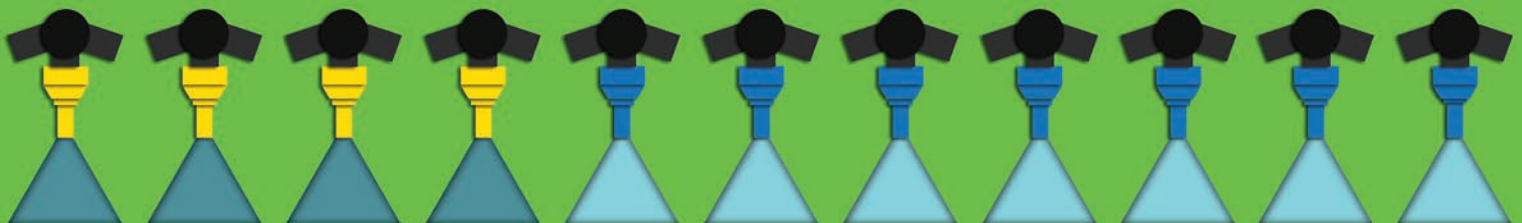

**4** application passes optimized with See & Spray targeted spray

leaving **7** passes of opportunity for future Sense & Act innovation



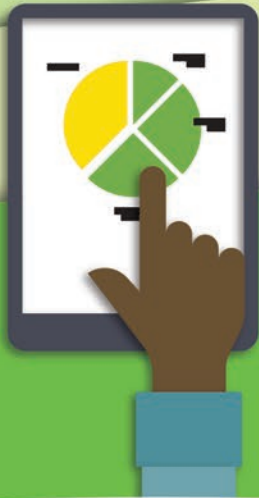

“Working with Deere helps customers more easily leverage what they’re already doing to unlock the potential for creating value down the road.”

— Jesse Daystar, Cotton Incorporated

## TURNING DATA INTO VALUE

In addition to completing the hard work in the field, John Deere “connected machines” — those connected to the John Deere Operations Center through JDLink™ telematics system — are also constantly capturing and transmitting data. Capturing this in-field information informs innovation and helps make production systems more efficient and sustainable. These digitally “engaged acres” can also unlock additional insights and value for growers.

Deere customer Trey Davis, owner of Davis Family Farms in Doerun, Georgia, operates approximately 4500 acres of cotton, 2500 acres of peanuts, and 600 acres of corn annually. The family-run farm uses John Deere Operations Center data to help with its sustainability journey by identifying underperforming acres that can be repurposed. For example, he recently converted 20 acres of land into a pollinator plot, which is a more economic and sustainable use of that land.

Deere is also working to enable our customers to leverage their data to access additional value associated with their sustainable practices and sustainable crops. One example involves the U.S. Cotton Trust Protocol (U.S. CTP).

Cotton buyers are increasingly demanding more sustainably grown cotton and more visibility into the practices used to grow that cotton. Established in 2020, U.S. CTP wants to build a coalition of sustainable cotton growers to meet these demands. To qualify for U.S. CTP, growers must complete

a sustainability analysis, which evaluates the sustainability of the customer’s production practices using the Field to Market® Fieldprint® calculator. Backed by the National Cotton Council and Cotton Incorporated, U.S. CTP then shares that aggregate information with cotton buyers — like clothing retailers — who can use this information to meet their own commitments related to sustainable products.

One of the key barriers to participation for growers is the hours it takes to enter manual data into relevant forms. This is where the John Deere Operations Center comes in. The John Deere innovation team is working to enable Operations Center customers to quickly import information and complete 60 percent of the form with the click of a button. And the remainder can be completed through a more streamlined process, eliminating most of the manual-entry requirements.

By building trust through providing visibility into the sustainable practices utilized by cotton growers, U.S. CTP can serve the growing demand by retailers for sustainably grown cotton. By eliminating the documentation hurdle required for participation, Deere can enable its customers to easily get real, tangible value from their sustainable growing practices. In this case, that value is access to markets for their cotton they may not have had before.



To see more of the story, visit [deere.com/en/our-company/sustainability/sustainability-report/cotton-production/](https://deere.com/en/our-company/sustainability/sustainability-report/cotton-production/)

# CONNECTED MACHINES SUPPORT SUSTAINABLE FOREST MANAGEMENT

To fully understand the importance of sustainable forest management, it's best to first understand the environmental and economic value of its crop.

Yes, trees are a crop.

For some, that is a difficult statement to understand, because trees are not like corn or soybeans. Once harvested, it takes years — not months — before the next harvest is ready.

## GOOD FOR THE PLANET

There is no better asset in the fight against climate change than trees. Forests purify the air we breathe, filter the water we drink, and reduce the planet's carbon footprint by storing carbon while releasing oxygen. In fact, almost as much carbon is stored in forests (650 billion tons) as is in the atmosphere (760 billion tons).<sup>1</sup> And, when trees are harvested and turned into building materials, that carbon is sequestered, making for a long-term storage solution, as one cubic meter of lumber can hold one ton of CO<sub>2</sub> for an average of 20 years.<sup>2</sup>

But harvesting doesn't mean leaving an empty shell in nature. On the contrary, as application of sustainable forest-management principles has increased, so has the available crop. According to the Global Forest Resources Assessment 2020, there are six-percent more living trees in forests in North America today than there were in 1990.<sup>3</sup>

This is largely because, as a renewable resource, sustainably managed forests are maintained and regenerated as part of multiyear harvest cycles that can continue into infinity and provide an endless supply of wood, fuel, and paper products. Proper forest thinning, soil maintenance, and clearing of dead trees also aid in new growth and can help lessen the impact of fires. Without thinning and cleanup, much of what fuels a forest fire is now at ground level, easily ignited, and rapidly spread. Economically, forests account for \$500 billion in products annually<sup>4</sup>, with a global economic value estimated at \$33 trillion a year.<sup>5</sup> Beyond simple lumber or paper, trees contribute to products used in nearly every facet of our daily lives, including bedsheets,

disposable diapers, oil filters, baseballs, cricket balls, life jackets, linoleum flooring, charcoal, and home insulation. And the Food and Agriculture Organization (FAO) claims 25 percent of the world's population — more than 1.9 billion people — rely on forest resources for their livelihood (e.g., construction, recreational uses of land, and timber harvesting).<sup>6</sup>

<sup>1</sup> Food and Agriculture Organization of the United Nations (FAO), <https://www.fao.org/forestry/communication-toolkit/7636/en/>.

<sup>2</sup> Food and Agriculture Organization of the United Nations (FAO), <https://www.fao.org/3/ac836e/AC836E03.htm>.

<sup>3</sup> Food and Agriculture Organization of the United Nations, Global Forest Resources Assessment 2020, page 46, Table 36, <https://www.fao.org/3/ca9825en/ca9825en.pdf>.

<sup>4</sup> The Business Research Company, Forestry and Logging Global Market Opportunities and Strategies Report, <https://www.thebusinessresearchcompany.com/report/forestry-and-logging-products-market>.

<sup>5</sup> Rainforest Alliance, What is Sustainable Forestry, <https://www.rainforest-alliance.org/insights/what-is-sustainable-forestry/>.

<sup>6</sup> United Nations, The Global Forest Goals Report 2021, <https://www.un.org/esa/forests/wp-content/uploads/2021/04/Global-Forest-Goals-Report-2021.pdf>.

**650B tons**

of carbon stored in forests

vs.

**760B tons<sup>1</sup>**

of carbon in the atmosphere

One cubic meter of lumber can hold **one ton** of CO<sub>2</sub> for an average of 20 years.<sup>2</sup>

There are **6 percent** more living trees in North American forests today than in 1990.<sup>3</sup>



To see more of the story, visit [deere.com/en/our-company/sustainability/sustainability-report/forest-management/](https://www.deere.com/en/our-company/sustainability/sustainability-report/forest-management/)

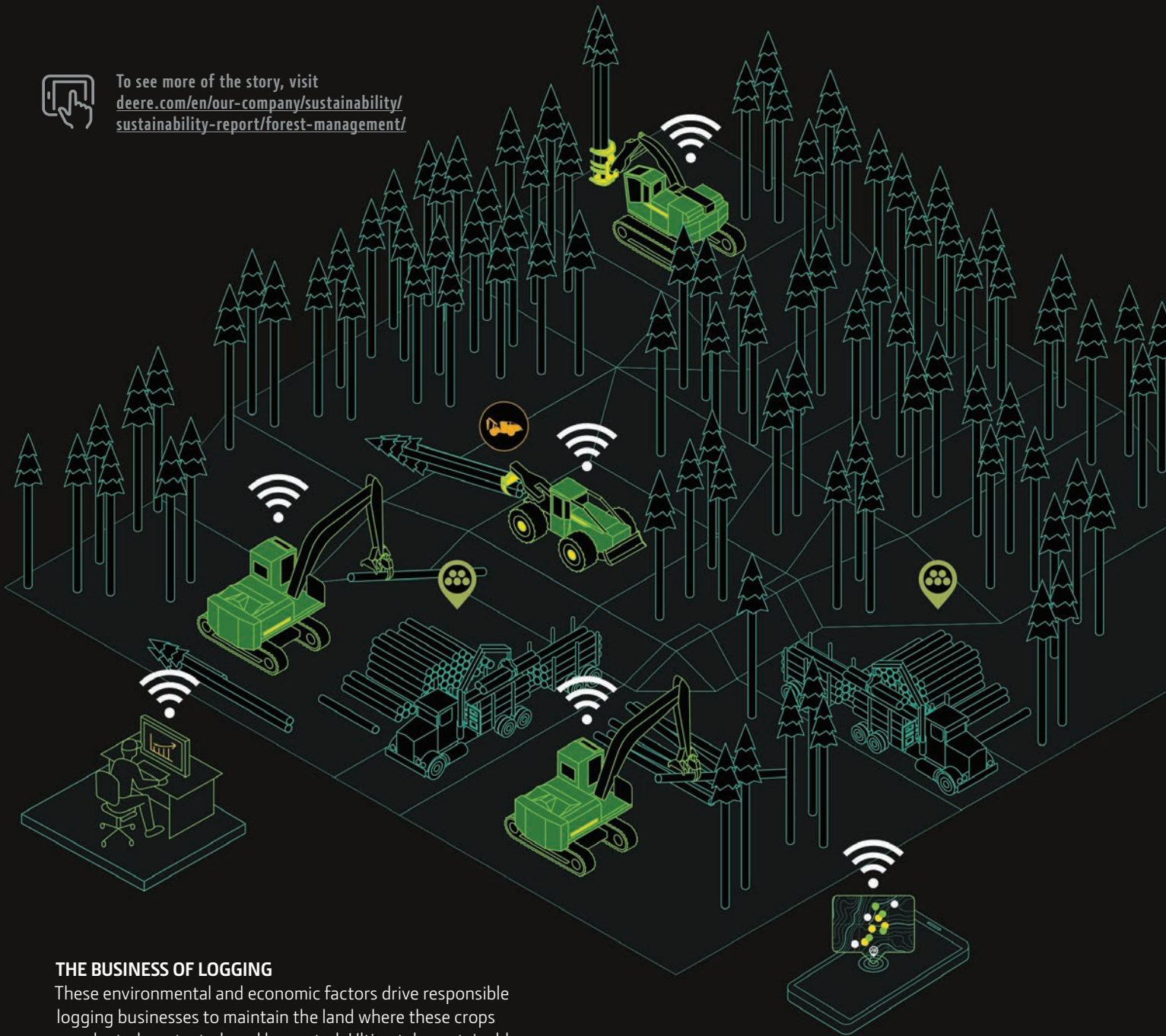

## THE BUSINESS OF LOGGING

These environmental and economic factors drive responsible logging businesses to maintain the land where these crops are planted, protected, and harvested. Ultimately, sustainable forest management is the practice of managing the growth, composition, structure, and quality of forests to meet society's values and needs, in a manner that enables the continued sustainability of those forests.

The United Nations estimates that in the next 30 years, population growth will require twice as much food and urban areas will house nearly 70 percent of the projected 10 billion people living on the planet. This means farmland will give way to development and the timber industry will continue to be pushed to the edges of desirable land.

Many logging operations already function on steep slopes, unforgiving ranges, and soil types that are not conducive to growing food or building communities. Challenges in this workspace include skilled labor shortages, safety, fleet management, and operation costs. As with any crop, customers want to be more efficient, reduce inputs like fuel, and maintain

the land they rely on. Using technology, we have the opportunity to assist our customers as they are felling, processing, extracting, and loading trees to be hauled to mills.

John Deere technology helps customers balance rugged demands with environmental concerns. For example, by utilizing TimberMatic™ Maps and Intelligent Boom Control (IBC), a logging operation not only gets the most from the crop but reduces the impact on the environment around it.

TimberMatic Maps leverages Deere's leading GPS technology to create a map-based production-planning and -tracking system. The software allows a contractor to set up a central command center that monitors all locations and tracks downed-tree placement — even when buried in snow — while minimizing disruption to environmentally sensitive areas. Alerts can be established so operators will be notified if they get too close to these designated locations.

This technology also allows for the design and real-time communication of the harvest plan, which means customers spend less time per load due to optimized path planning, increased load efficiency, and reduced driving distance per load. This can help reduce the number of passes a machine makes in the forest by up to 15 percent, which aids soil health and regrowth through reduced compaction.

John Deere innovation also makes workforce management easier for our customers. By simplifying complex tasks and movements on the machines, a larger variety of operators with varying skill levels can operate the machines and still deliver optimum results, all while spending less time on a job. Used by harvesters in the felling (or cutting) stage and on forwarders for extractions, IBC is a technology that enables operators to control the boom on our machines as if it is a human arm. The controls used for reaching and securing trees for harvest intuitively mirror how that piece of equipment might function if it was actually the operator's arm. This allows the operator to be 10-percent more efficient, which translates into both fuel and time savings.

To understand the impact of these technologies, consider a model worksite operation in the Scandinavian forest. Here a logging operation and its team are harvesting 2,500 cubic meters, which takes the team about 11 days to complete on average.<sup>6</sup> By combining these technologies — TimberMatic™ Maps and IBC — this customer can save approximately \$3,000 in operating expenses, reduce fuel usage by up to 156 gallons, and time on site by up to 40 hours. These outcomes reduce greenhouse gas emissions by about two metric tons (equivalent to eliminating 4,900 to 5,000 passenger vehicle miles). All in just 11 days, on just one of many jobs completed throughout the year.

<sup>6</sup> Using Deere technology and Wheeled Cut-to-Length Equipment on 2,500- cubic meter Scandinavian worksite, operating two shifts per day, average 11 working days to complete harvest.

<sup>7</sup> Outcomes based on customer experience and machine data. Results reflect savings achieved during processing of 2,500 cubic meters with a typical team working two shifts per day, which would take approximately 11 days on average. Results will vary.

<sup>8</sup> Equivalencies based on U.S. Environmental Protection Agency Greenhouse Gas Equivalencies Calculator, <https://www.epa.gov/energy/greenhouse-gas-equivalencies-calculator>.



## SUSTAINABLE OUTCOMES DELIVERED BY JOHN DEERE TECHNOLOGY

*Outcomes realized per 2,500-cubic-meter model worksite<sup>7</sup>*

**156** GALLONS  
of fuel saved

**40** LESS HOURS  
of labor to complete job

**\$3,137**  
cost savings to operator  
(fuel + labor)

**2** metric tons CO<sub>2</sub>e reduced

Equivalent to offsetting 5,000 passenger car miles driven or adding 2.5 acres of forest sequestering carbon<sup>8</sup>

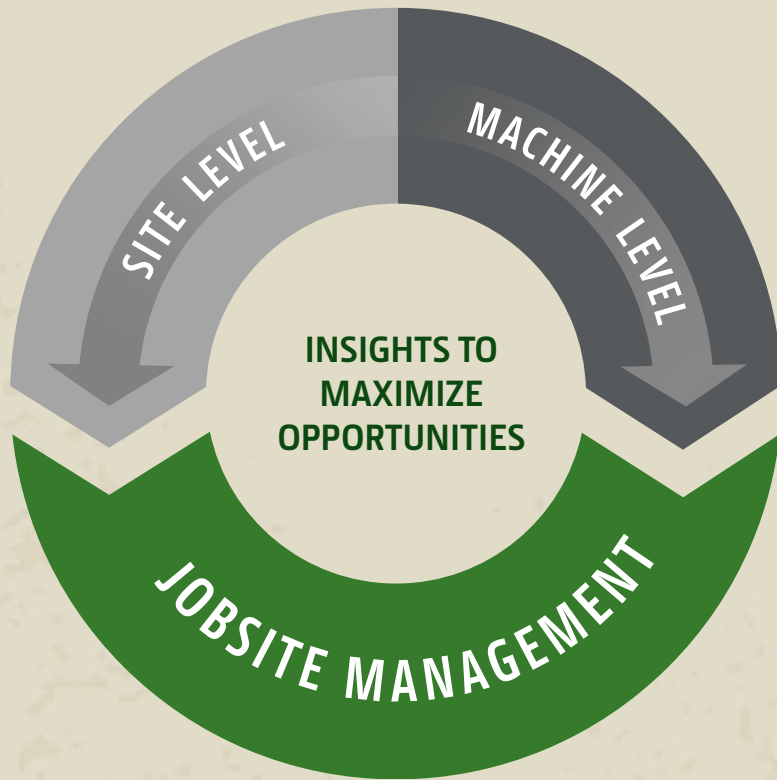

## TimberMatic™ Maps



Production Tracking



Visualized Production Data



Digital Map Layers



Site Progression



Connected Insights



A green CH950 sugarcane harvester is shown from a front-facing perspective, positioned in a sugarcane field. The machine's large, circular harvesting heads are prominent at the top. The harvester is surrounded by harvested cane stalks on the ground and standing cane in the background. The sky is clear and blue.

# CH950

BOOSTS EFFICIENCY, SUSTAINABILITY  
OF SUGAR CANE HARVEST

Sugar cane farming in Brazil is a tricky tightrope of coordination, safety, and efficiency due to the scale of operations, stringent regulations, and the orchestrated chaos of machinery and people.

To keep a large sugar cane operation running, our customers may manage over 1,000 employees and more than 40,000 hectares (roughly 100,000 acres), in addition to over 20 harvesters, 40 tractors hauling harvested cane out of the field, and five or more refueling trucks driving back and forth to keep the harvesters running 24 hours a day.

And while sugar cane as a crop is known for its importance in the food industry, in Brazil it is equally – if not more so – valuable to the renewable-fuel industry as the country sharpens its focus on greenhouse gases. With roughly 80 percent of the country’s auto fleet tied to flex-fuel blends, more than 50 percent of sugar cane is used for ethanol.

When compared to more widely visible crops – like corn and soybeans – sugar cane is unique as it regrows off its own stubble or remaining stalk, making it truly sustainable unto itself. This regrowth means one sugar cane plant can provide up to five years of harvest opportunity. But if the stalk is ripped from the ground, that yield potential is gone for good, which means a clean cut of the plant is critical.

Given the significant role that harvest plays in the sugar cane production system, any pain points throughout this phase have a potentially outsized impact on growers. Those challenges include high fuel-input costs, high fuel-transport costs, logistics, soil compaction, and yield impacts.

In response, John Deere created the CH950 Sugar Cane Harvester.

Launched in 2021, the CH950 is the first mass-produced independent two-row sugar cane harvester in the industry. Previous models allowed for harvesting only one row of cane at a time because of the sheer weight of the crop. Average sugar cane yields are 80–100 tons per hectare, and an average one-row sugar cane harvester operates 3,000 hours per year at 40 tons per hour. By comparison, this means the volume of material processed by a one-row sugar cane harvester per season is six times more than an average corn harvester processes per harvest. By adding the second row, the volume of material a single sugar cane harvester must process per season nearly doubles.

When creating the two-row CH950, John Deere engineers addressed the challenge of increased volume with SmartClean™ system and RowAdapt™ technology. This technology allows the cane harvested from the dual rows to merge in the machine right after the plant is cut. The harvester then conveys the cane up into a narrow shaft, which enables control of the crop, allowing SmartClean to clean it more effectively. SmartClean allows for less cane loss, lower fuel consumption, and reduced trash within the crop.

While nearly doubling the intake of crop is an impressive and welcome outcome, the impact of the CH950 goes way beyond productivity.

Previous single-row models meant a six-foot-wide harvester had to work in a five-foot-wide row spacing. The challenges associated with this mismatch were multiple.

“It created soil compaction issues as growers traveled over the same row spacings multiple times, and it also damaged root beds and caused poor cutting of the crop,” said Jesse Lopez, global sugar cane business manager at John Deere.



The width of the previous machine form often meant the harvester's tracks rode up along the plant's root structure and would lift the stalk out of the ground when cutting the plant. This often hindered the plant's chance for regrowth. The rebalanced CH950's wider base aligns the harvester's tracks directly in the center of the rows, allowing for a 60-percent reduction in soil compaction as the machine only travels certain row spacings once and other row spacings not at all.

The CH950 also increases the likelihood the typical five-year growth cycle for the plant can be extended to seven or even eight years. By extending the replanting cycle, there are benefits beyond increased yields; this also delivers savings in input costs like seed and fuel, which also reduces the overall environmental impact of the production cycle. "There are so many benefits," Lopez added. "When you look at the savings over that typical five-year cycle, it is really meaningful. Adding one more year to the cycle could mean up to an additional 20 percent in reduced costs and a positive impact on sustainability."

Stacked on top of these benefits is an immense fuel savings and logistics benefit associated with the CH950. By nearly doubling the productivity of each machine, the CH950 has improved fuel efficiency by up to 17 percent.

An added wrinkle in Brazil are regulations that prohibit refueling in the field after dark, a pain point for sugar cane growers as previous models of harvesters required refueling twice every 24 hours. The CH950 solves this problem with both increased fuel efficiency and fuel-tank size. This new machine can be refueled once per 24 hours, which means the challenge of timing the last refueling during daylight hours is reduced, and the overall number of trips to the field for refueling is cut by 25 percent, delivering a significant fuel and greenhouse gas emissions savings for the operation.

This impressive increase in productivity of a single machine reduces the number of harvesters needed to do the same job by a staggering 50 percent. For our model-farm operation, this means 11 machines instead of 22. The extra row also means up to 27-percent fewer tractors are needed to move the cane from the harvest wagon to the transport trucks. And fewer machines in the field means a reduction in the number of operators of approximately 35 percent.

Felipe Dias, product manager for sugar cane, said it's about being able to do more with less. "We will be able to produce the same amount of sugar and the same amount of ethanol with fewer resources," he said. "That is the definition of sustainability."



To see more of the story, visit [deere.com/en/our-company/sustainability/sustainability-report/ch950-sugar-cane-harvest/](https://www.deere.com/en/our-company/sustainability/sustainability-report/ch950-sugar-cane-harvest/)





# CH950 SUGAR CANE HARVESTERS DELIVER SUSTAINABLE OUTCOMES ACROSS THE ENTIRE PRODUCTION SYSTEM:<sup>1</sup>

**1.1M** LITERS of fuel saved (300,000 gallons)

**3,600** METRIC TONS CO<sub>2</sub>e reduced

• This translates into over **9 million miles** driven by average passenger vehicle<sup>2</sup>

**52,000** additional tons of sugar cane harvested due to reduced losses

**11,500** KM of reduced driving (7,145 miles)

**150,000** fewer hours of labor

Economic value to the producer of  
**R\$18,000,000** or **USD\$3,000,000**

<sup>1</sup> These outcomes are based on a model sugar cane farm operating in Brazil on 42,000 hectares. These figures represent the outcomes realized per harvest operating CH950 Sugar Cane Harvesters across the entire operation. Results based on testing conducted in conjunction with the University of São Paulo State (UNESP-NEMPA). Results will vary.

<sup>2</sup> Equivalencies based on U.S. Environmental Protection Agency Greenhouse Gas Equivalencies Calculator, <https://www.epa.gov/energy/greenhouse-gas-equivalencies-calculator>.

# SEE & SPRAY™ SELECT SYSTEM SAVES (AND TARGETS) GREEN

The heartbeat to any agronomic solution starts with being able to do more with less. More ground covered in less time. More options with less headache. And more yield with less input cost.

See & Spray Select adds one “more” to that list: more weed control with less chemical use.

See & Spray Select continues to advance the precision agriculture landscape by using sophisticated camera and nozzle-control technology from the ExactApply™ sprayer system foundation to transition from managing by field to zone to row and, eventually, to individual plants. Or, in this case, weeds — the enemy of increased profitability.

Available on new John Deere 400- and 600-Series Sprayers, See & Spray Select provides an innovative targeted broadcast-spraying solution.

Used on unplanted ground, the “green-on-brown” technology differentiates color and can distinguish green from soil. When green is detected, spray nozzles are activated in varying degrees based on target rates needed.

On average, See & Spray Select can reduce contact herbicide usage by up to 77 percent while still hitting 98 percent of the weeds in the field — essentially the same rate as broadcast spraying.<sup>1</sup> Savings are quickly accessible by the operator on the See & Spray dashboard via the in-cab display. In addition, the display provides a coverage map of areas traveled where herbicide was not applied. The display streams this data to the John Deere

Operations Center, which provides customers with a field map of herbicide application and quantifies outcomes like acres not sprayed and herbicide savings.

By using fewer inputs, the need to refill is reduced, allowing farmers to cover more acres in a day.

The overall savings can help justify the use of more expensive and complex tank mixes to manage herbicide-resistant weeds. Studies have proven that when more than two modes of action are used, weeds are 83 times less likely to develop herbicide resistance, making it more cost effective to use.<sup>2</sup>

What’s more, engaging the technology to switch from broadcast application to See & Spray Select’s precision application is a seamless integration made from inside the cab.



<sup>1</sup> In tests over 75,000 acres of fallow ground, typical weed pressure of 3,000 weeds per acre, with spray-length settings of small or medium, customers experienced an average herbicide savings of 77 percent when compared with a broadcast sprayer.

<sup>2</sup> Based on Evans JA, Tranel PJ, Hager AG, et al., Managing the evolution of herbicide resistance. *Pest Manag Sci*; 2016;72:74–80.

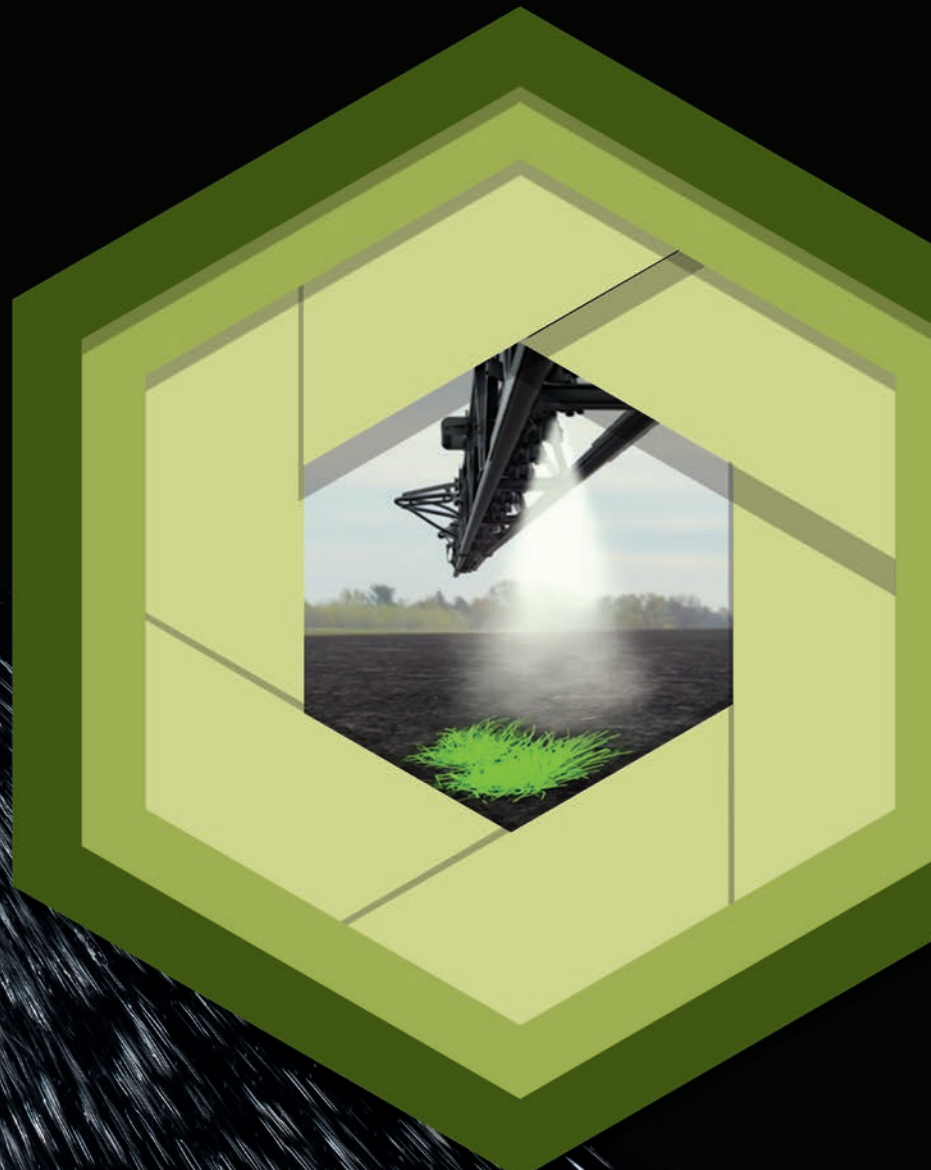

**77%** less contact herbicide

# AN OPPORTUNITY THE SIZE OF OUR FLEET: PERFORMANCE UPGRADES PROMOTE SUSTAINABILITY

The average age of equipment in North America is historically high, and John Deere wants to provide solutions that upgrade the technology, performance, and sustainability of the entire fleet. To extend the useful life of products, customers can add technology and components that improve the performance and sustainability of machines beyond their original capacity.

Performance upgrades allow customers to operate new technology without new equipment purchases. This balances productivity and capital expenditure to ultimately benefit a customer's bottom line.

These innovative solutions also support a circular economy, which is based on the idea that we can eliminate waste. To achieve circularity, products are designed to last and optimized for disassembly, transformation, and renewal. This system encourages the preservation of natural resources, the reduction of energy consumption, the introduction of fewer plastics into the waste stream, and smaller carbon footprints overall.

What's more, performance upgrades enable our dealers to serve customers more efficiently because technicians are working on machines and technologies they know well. When customers add updated John Deere technology to their machines, it works on their existing machine displays and seamlessly transfers their data to the John Deere Operations Center. It also allows farmers to get connected support, communicate with their trusted advisors, and make informed decisions for the future of their businesses.

"When it's all [John Deere] green, it reduces downtime for our customer, which is critical when the window to complete their job can be small. They come to a solution provider who adds seamless technology integration, making the John Deere dealer the recognized expert to have customer problems resolved," Miles Keaton, director for Performance Upgrades, said.

On top of adding value for customers, performance upgrades represent a significant business opportunity. There are 150,000 tractors, 70,000 planters, 50,000 sprayers, and 90,000 combines sowing, protecting, and harvesting U.S. and Canadian crops each year. Deere can provide updates to planters back to 2005 and sprayers back to 2014. Kits for older model years and additional equipment are in development.

Deere currently offers 12 performance upgrades to the row crop planter product line, with particular focus on ExactEmerge™ row units, ExactRate™ liquid fertilizer, and Individual Row Hydraulic Downforce (IRHD). Customers select these upgrades to reduce inputs and achieve a better yield with uniform emergence and consistent seed depth across varying soil types. Deere also offers 10 performance upgrades to sprayers, the most popular example of which is ExactApply™, which provides precision droplet control in liquid application to dramatically reduce overuse.



## OUR PERFORMANCE UPGRADES MISSION:

Shorten the technology-adoption curve, promote sustainable operations, and unlock customer economic value.

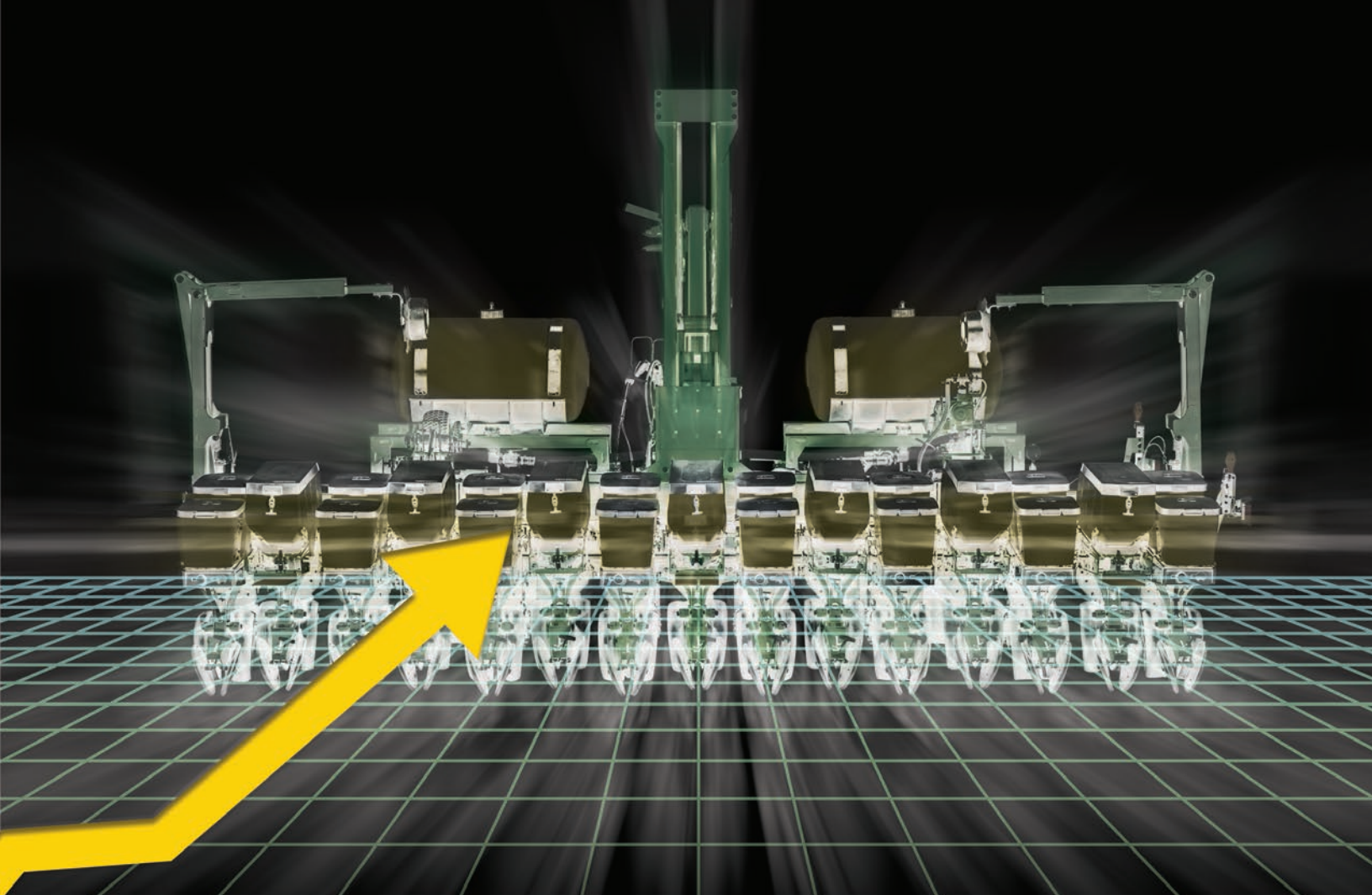

The planting step is perhaps the most critical pass of the year for a farmer. The largest single impact that a planter has on corn yield is the ability to control the depth of the row unit. Customers with a 2005–2013 planter — before ExactEmerge row units and other advancements became available — can see more consistent seed depth and uniform emergence by adding IRHD and ExactEmerge. These Performance Upgrades can result in a significant increase in corn yields if done correctly.

And while yields are increasing, inputs are decreasing. ExactEmerge accurately spaces each seed to achieve 99-percent singulation, meaning higher yields are achieved with fewer seeds planted. While the seed is planted, ExactRate liquid fertilizer system applies liquid fertilizer with precision, reducing overlaps and applying the proper rate across a field. These technologies can operate at double the speeds of conventional planters through the field. This reduces the time required to plant and ensures the seeds are planted in the optimal planting window for maximum yield potential.

ExactApply sprayer system or nozzle control is our most common Sprayer Upgrade Technology, with the most advanced nozzle control on the market. Once in the field, this technology enables customers to place chemicals exactly

where the plant needs it. This reduces overall chemical usage without sacrificing yield and provides benefits for both the customer's business and their environment.

The key feature of ExactApply is precise droplet-size control over the widest range of operating speeds in the industry using Pulse Width Modulating (PWM) technology. This allows farmers to reduce overapplication and improve accuracy, all while saving two to five percent on herbicide and pesticide use and conserving water. This sprayer upgrade will cover more acres faster, allowing customers to get the benefits of the newest sprayer technology with the equipment they already own.

Armed with these capabilities and an understanding of our customers' needs, Deere's mission becomes rather simple: Shorten the technology-adoption curve, promote sustainable operations, and unlock customer economic value by installing the latest technology on later-in-lifecycle equipment.

Better technology. Better solutions. Better yields. All while keeping our planet in better health.



To see more of the story, visit [deere.com/en/our-company/sustainability/sustainability-report/performance-upgrades/](https://www.deere.com/en/our-company/sustainability/sustainability-report/performance-upgrades/)



**ENVIRONMENTAL**

# CLIMATE STEWARDSHIP

Reducing greenhouse gas (GHG) emissions that are contributing to climate change requires the commitment of many to invest, innovate, and create solutions that don't exist today. It requires all of us to look at our businesses and operations, and drive innovations that help reduce our own GHG emissions footprint. But it will take much more than that. It also means creating machinery and equipment with reduced tailpipe emissions and leveraging biofuels and renewable fuels. And it means that we at John Deere must enable our customers, through technology and data-driven decision-making tools, to understand and reduce their own GHG emissions footprint.

This is where John Deere is uniquely positioned to lead the way. We see the global transition to a low carbon economy as a significant strategic opportunity for our business and for our customers — whether that be through increased demand for sustainably grown grains, biofuels made from sustainably

grown grains and oilseeds, or low-carbon solutions on earthmoving and roadbuilding worksites — our technology and solutions can and will enable our customers to participate in these economic opportunities. That alignment of sustainability and economic opportunity is what we believe will drive the necessary change and adoption.

This year we completed the analysis necessary to publish our first Task Force on Climate-related Financial Disclosures (TCFD) Report. For additional detail on our governance, strategy, risk management, and metrics and targets related to climate change, please refer to our [TCFD Report](#).





## OPERATIONAL GHG EMISSIONS: SCOPES 1 AND 2

As part of our 2022 Sustainability Goals, we committed to reducing our absolute GHG emissions by 15 percent from our baseline of 2017 through the utilization of at least 50-percent renewable electricity. And we are on a path to exceed this goal. In 2021, we achieved 20-percent reduction in GHG emissions from 2017 baseline and 40.5-percent renewable electricity.<sup>1</sup> Key drivers of the reductions we saw this year included: the implementation of more than 40 energy-efficiency projects globally, in lighting and controls, compressed air, and manufacturing processes; the continued greening of our electricity supply; and an employee focus on eliminating energy waste. For 2021, our enterprise Scope 1 GHG emissions were 403,300 metric tons and our Scope 2 GHG emissions were 407,700 metric tons.

But we aren't finished yet. As part of our newly launched Leap Ambitions, we have recommitted to reducing our Scope 1 and 2 GHG emissions, this time by an additional 50 percent from 2021 levels and submitting this target to Science Based Targets initiative for approval. To achieve this goal, John Deere will continue to focus on energy efficiency while transitioning to low-carbon energy sources like onsite renewable solutions and partnerships for offsite renewable projects.

### John Deere India: Leading in Renewable Electricity

As John Deere continues to progress on achieving its 2022 Sustainability Goals, there are several bright spots aiding its success. One such example resides in India. John Deere's global Sustainable Energy Use goal is getting impressive engagement, and results, from the team at the company's manufacturing facility in Pune, India.

The Pune team's engagement began with a large offsite wind-supply agreement more than 10 years ago. Today, our Pune facility is also home to one of the enterprise's largest onsite solar installations. This has positioned Pune as an early leader in the company's renewable-electricity efforts in a strategy balancing onsite and offsite power solutions with long-term solutions. The Pune site is well on the way to having more than half of its electricity come from renewable sources by the end of 2022, which is the GHG emissions equivalent of removing over 2,000 passenger vehicles from the road per year.<sup>2</sup> Our India team is executing on a strategy to continue to grow the long-term renewable-energy supply for all our key India locations.

<sup>1</sup> Data associated with the operation of PLA Holding Netherlands B.V., Mazzotti S.r.l., and King Agro Europa, S.L., and their related subsidiaries, and the Wirtgen Group entities are included for all years in the reported metrics. Data associated with the operation of Unimil is not included in the reported greenhouse-gas and renewable-electricity metrics.

<sup>2</sup> Equivalencies based on U.S. Environmental Protection Agency Greenhouse Gas Equivalencies Calculator, <https://www.epa.gov/energy/greenhouse-gas-equivalencies-calculator>.



## SUPPLY CHAIN AND USE OF SOLD PRODUCTS GHG EMISSIONS: SCOPE 3

During 2021, we calculated our Scope 3 GHG emissions. Through this process, we identified Category 1 (Purchased Goods & Services) and Category 11 (Use of Sold Products) as the two categories where we have the greatest opportunity to reduce GHG emissions impact. Our Scope 3 emissions, represent 99 percent of our overall GHG emissions and our Category 11 emissions are over 92 percent of our total GHG emissions. For 2021, our total Scope 3 GHG emissions were 112,453,000 metric tons.

Based on our calculations, we have committed to submit a plan to the Science Based Targets initiative for approval that includes a 30-percent reduction in our Scope 3 GHG emissions by 2030. To achieve this, we will collaborate with our supply chain partners to find opportunities for them to reduce their GHG emissions. Additionally, we are committed to developing products, technologies, and solutions that address the emissions of the products we produce. We will be doing

research and development on a variety of avenues for alternative solutions related to machine propulsion — this will include electrification, renewable fuels, and biofuels. We have already started the journey of electrification, and our construction and forestry group is leading the way on a recent project.



### E-Power Backhoe: A Key Step in Our Electrification Journey

John Deere's continued innovation of electrified equipment now includes its introduction of the E-Power Backhoe, a battery-electric prototype built off the current 310L 100-horsepower diesel equivalent.

Spurred by interest from National Grid — an electricity, natural gas, and clean-energy-delivery company based in the northeast United States — the E-Power Backhoe will utilize its cleaner power source to reduce CO<sub>2</sub>e emissions and diesel fuel consumption over the life of the product.

Currently in Phase I proof of concept, the E-Power Backhoe is being put to work in real-life jobsite scenarios. By leveraging the company's previous product successes and the Construction & Forestry Division's hybrid-electric loader line, the backhoe team was able to move quickly in getting a prototype into field-testing in less than one year. Deere expects to leverage insights from the E-Power Backhoe across multiple product lines to have not only a backhoe but multiple machine forms that incorporate electrification, putting Deere on a path to revolutionizing the earthmoving fleet.



To see more of the story, visit  
[www.deere.com/en/our-company/sustainability/sustainability-report/e-power-backhoe/](http://www.deere.com/en/our-company/sustainability/sustainability-report/e-power-backhoe/)

## BEYOND OUR OWN EMISSIONS

While we work to reduce our own GHG emissions, John Deere is committed to delivering value to our customers through cutting-edge technology and solutions that will make their operations more sustainable and lower their GHG emissions. The production systems we serve are complex operations that have multiple sources of GHG emissions beyond the tailpipe emissions associated with their equipment and machinery. For example, in agriculture other contributors include fertilizers, herbicides, fungicides, logistics and transportation, and drying activities. In addition, agriculture has the potential to transform from a net emitter of carbon to a net offsetter of carbon through reducing inputs and changing practices. For example, reducing tillage passes, nutrient management, and cover cropping all have the ability to enable our customers to sequester carbon in their soil — and potentially get compensated for it as new markets evolve, such as premium commodity markets for sustainably grown grains or new sustainability ecosystem markets.

This is why our Leap Ambitions encompass not only our own emissions, but also focus on helping reduce our customers' inputs and emissions. Our investment in solutions for our customers can both have an impact on GHG emissions and unlock additional economic opportunities.

John Deere offers products and technologies in the market today that already reduce the GHG emissions of our customers' operations. Our technologies optimize passes and reduce inputs like fertilizer and herbicides through precise application. Less inputs and fewer passes translate into lower GHG emissions.

And we have a roadmap of additional technologies and solutions that will build upon these outcomes. We are also engaging closely with our customers to more clearly understand the science and pain points behind soil-carbon management and carbon sequestration.

## ExactRate™ Liquid Fertilizer Systems Optimizes Nutrient Stewardship

When agricultural customers discuss input costs, fertilizers are a critical topic. Centered in that discussion are the four R's of nutrient stewardship — right time, right rate, right source, and right place. Deere's introduction in 2021 of the integrated ExactRate liquid fertilizer solution helps address each one.

The factory-installed system takes advantage of existing John Deere technology — ExactEmerge row units, variable-rate capability, curve compensation, and row-by-row control — to allow farmers to apply nutrients at the most optimal time of the year — when the seed is going into the ground. By integrating ExactRate with the ExactEmerge planter, customers can now plant their seeds and apply fertilizer in the same pass.

Prior to ExactRate, time constraints in the spring led many customers to apply fertilizer in the fall when time was more plentiful. However, winter snow melt and spring rains often caused nitrogen leaching, which takes the fertilizer from the soil and washes it away. By removing the extra pass required to apply spring fertilizer, ExactRate is a critical step toward optimizing, and ultimately reducing, fertilizer application.

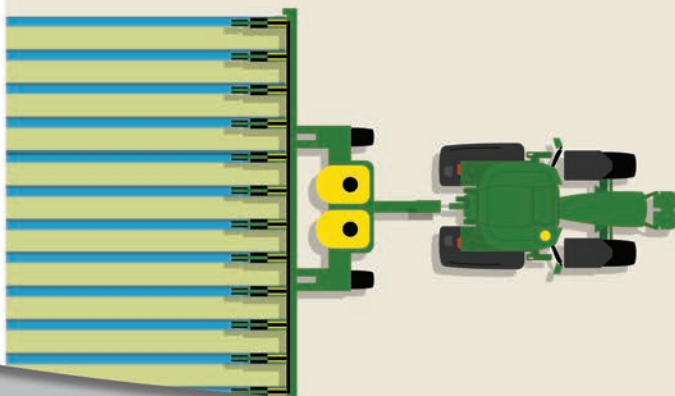

## Carbon Pilot Program Focuses on Data, Agronomics



In early 2021, John Deere began a carbon pilot program with two goals in mind — helping customers improve their agriculture businesses beyond crop yield and continuing its impact on the environmental aspects essential to their operations.

The pilot aimed to utilize Deere's ever-increasing data-collection prowess (currently at more than 315 million engaged acres globally) to educate and assist customers regarding the agronomic benefits of carbon capture and the possibility of earning carbon credits for their efforts.

Currently, 15–20 U.S. customers, with a representative total of 5,000 acres, are working with Deere to better understand sustainability markets, such as carbon markets, and how best to navigate through them as a customer. In addition to helping customers leverage the sustainability benefits of Deere precision technology tools, the pilot is also focused on assisting customers with two primary practices that are being utilized for overall soil health and carbon sequestration — cover cropping and no-till practices.



## PRODUCT CIRCULARITY

John Deere provides solutions that are not only more productive and efficient, but also minimize impact on the environment. During the whole life of the product, from design to end-of-life, we enhance the environmental sustainability of our products. From our 2022 Product Sustainability goals to our new Leap Ambitions, John Deere continues to focus on using less and better, using longer, and using again.

Our 2022 Product Sustainability goals include reducing the environmental impact, such as CO<sub>2</sub>-equivalent emissions, on 90 percent of our new product programs as well as increasing remanufacturing revenue by 30 percent with a baseline year of 2017. In 2021, 71 percent of our new product programs incorporated goals to lower the environmental impact compared to the previous comparable model, and our remanufacturing revenue was 16.3-percent higher than 2017.

Our newly launched Leap Ambitions place a renewed emphasis on product circularity. We have committed that by 2030: 95 percent of the materials (by weight) in our products will be recyclable, 65 percent of the content (by weight) going into our machines will be sustainable, and our remanufacturing revenue will be 50 percent higher than in 2021.

### USE LESS AND BETTER

We continually strive to improve productivity, enhance fuel efficiency, reduce material usage, increase sustainable-material usage, and design for remanufacturing. John Deere's products incorporate various sustainable materials such as recycled content, renewable materials (i.e., soy-based resin), and low-carbon materials that provide many benefits. Sustainable materials lower the product's environmental impact, can reduce product weight, and enable the incorporation of our own customers' products within our machines. We will continue to work on building our sustainable-materials usage to achieve our Leap Ambition of sustainable materials comprising 65 percent of our products by weight.

### USE LONGER

Even with the long life of our products today, we continue to innovate to further extend our product lifecycles. John Deere has three processes by which to extend the useful life of our products — performance upgrades, rebuild, and remanufacturing.

### PERFORMANCE UPGRADES

John Deere has aggressive goals to enable customers to improve the efficiency and accuracy of their existing machines while minimizing the impact on the environment via the reduction of inputs. By upgrading older vehicles, such as a planter with ExactEmerge™ row unit or a sprayer with ExactApply,™ the customer can improve yields and reduce input costs while reducing the environmental impact of their work.

## REBUILD

The John Deere Powertrain ReLife Plus program is a machine-rebuild program that extends the life of our construction customers' machines. Starting with a thorough machine inspection by a certified John Deere technician, the machine is rebuilt to include a complete set of John Deere Reman powertrain components and then covered by a standard one-year warranty on all John Deere Reman components. On the ag side of our business, sugar-cane and forage-harvester customers in the U.S. and Europe also can rebuild their machines, thereby extending the life of the product. A longer life for our machines means existing equipment can stay in use longer, extending replacement frequency and reducing the overall environmental impact of each machine.

## REMANUFACTURING

Remanufacturing reduces John Deere's impact on the environment by reducing our reliance on raw materials through the reuse of parts. This enables us to eliminate waste and reduce energy use compared to manufacturing new parts. By bringing parts back to the original specification, our John Deere Reman business provides quality remanufactured products such as engines, drivetrains, hydraulic and electronic components to agricultural, construction, and forestry customers at a lower price point than new parts and provides alternatives to customers looking for value and uptime. Customer acceptance of remanufactured parts continues to grow, and the environmental message associated with remanufacturing is resonating on a global level. Our continued focus on growing the remanufacturing business is reflected in our Leap Ambition focused on growing remanufacturing revenue an incremental 50 percent by 2030 with 2021 as the baseline.

## USE AGAIN

We design each of our machines so that when it reaches the end of its useful life, which can no longer be extended, most of its parts, components, and materials can be reused again in other products or recycled. We aspire to use high rates of recyclable material and create recycling streams that ensure the circularity of our products — this directly connects to our Leap Ambition of achieving 95 percent of recyclable content in our products by weight by 2030.



## Deere, REMADE Work to Strengthen Circular Economy

John Deere has increased its representation within REMADE — a public-private partnership established by the United States Department of Energy — by contributing toward the program's initial \$140-million investment, making the company one of 35 Tier 2 members. By linking John Deere Reman to REMADE, the company continues its efforts to promote a circular economy and accelerate getting solutions to market. The Tier 2 status allows Deere to have representation on REMADE's governance board, access to federal funding, and participation in full projects.



To see more of the story, visit [deere.com/en/our-company/sustainability/sustainability-report/circular-economy/](https://deere.com/en/our-company/sustainability/sustainability-report/circular-economy/)





## RESPONSIBLE WATER USE

Our current water goal is to implement water Best Management Practices in all our water-scarce locations. In 2021, 80 percent of the best management practices have been implemented at our water-scarce facilities.<sup>1</sup>

Water is a vital component of our global manufacturing operations. Areas faced with the potential for water scarcity are our main priority. Using the World Resources Institute Aqueduct Water Risk Atlas tool, 17 John Deere manufacturing sites were determined to be in areas of water scarcity, mainly in Mexico, India, and China.<sup>1</sup>

Pursuant to our commitment to achieve our 2022 Sustainability Goals, our manufacturing sites in these areas must implement applicable Best Management

Practices. These Best Management Practices may include actions like: site-specific water-management strategies, employee-education and -awareness programs, and review of existing operations for efficiency opportunities.

John Deere Dewas Works in Dewas, India, has reduced the intensity of water consumed more than 50 percent since fiscal year 2018 by focusing on reducing fresh water use in operations, optimization of water usage in the paint system, installing touch sensors, employee awareness, and reuse of water. One-hundred percent of the manufacturing facilities in India are zero discharge for wastewater, meaning the water consumed for operations is reused within the operation or facility.

Even though our goal is focused on water-scarce locations, our commitment to using water responsibly is a critical part of the way we operate all our global facilities. These facilities are required at a minimum to develop and review a water-management strategy annually and develop and implement an employee-engagement and -awareness campaign.

Looking forward to our Leap Ambitions, we will continue to focus on reducing fresh water consumption where it matters most, at our manufacturing locations in water-scarce areas. Deere is committing to reduce the water intensity in our manufacturing operations in water-scarce areas 10 percent by 2030.

<sup>1</sup> Data associated with the operation of PLA Holding Netherlands B.V., Mazzotti S.r.l., King Agro Europa, S.L., and Unimil, and their related subsidiaries, and the Wirtgen Group entities, are not included in the reported metrics.



## WASTE ELIMINATION

Our current recycling goal aims to recycle 85 percent of our waste from operations by 2022. In 2021, 83 percent of our waste was recycled.<sup>1</sup>

Facilities have established waste-management programs that provide guidance for how to comply with waste-management requirements while increasing recycling. Once waste and recyclables are separated, our facilities work with approved suppliers to ensure they are recycled or reused. We have processes in place to monitor our suppliers to ensure that we know where our waste and recyclables are ending up.

One of the largest leftovers of the manufacturing process is steel. Steel and scrap metal are not included within our waste reporting because they are commodities with established markets and associated economic value. Therefore, we recycle these materials through the resale process.

Moving forward, the focus will be looking beyond the disposal method and proactively looking to reduce waste generation in our operations. We are committed to reducing waste intensity from our operations 15 percent by 2030.

### Recycling Leads to Steel Independence at the Waterloo Foundry

With the acquisition of three scrap-metal-processing machines, the John Deere Waterloo Foundry Operation is moving closer and closer to scrap-steel independence and the ultimate recycling success.

Historically, the purchase of the iron and steel required for metal castings often meant working with outside sources to obtain the needed materials. Now, however, more and more of the shavings, sheets, and castings are coming from Deere facilities.

To achieve this, in 2021, the Foundry added a briquetter for metal shavings, a shear machine for processing spent sheets of metal used during laser cutting, and a casting crusher used on large castings found right in Waterloo's own backyard.

**"While still in the early stages, the Foundry is already seeing improved quality in the output from reusing their own scrap. This is good for Deere and good for the environment." — Brian Harmon, Business Unit Manager**





**SOCIAL**

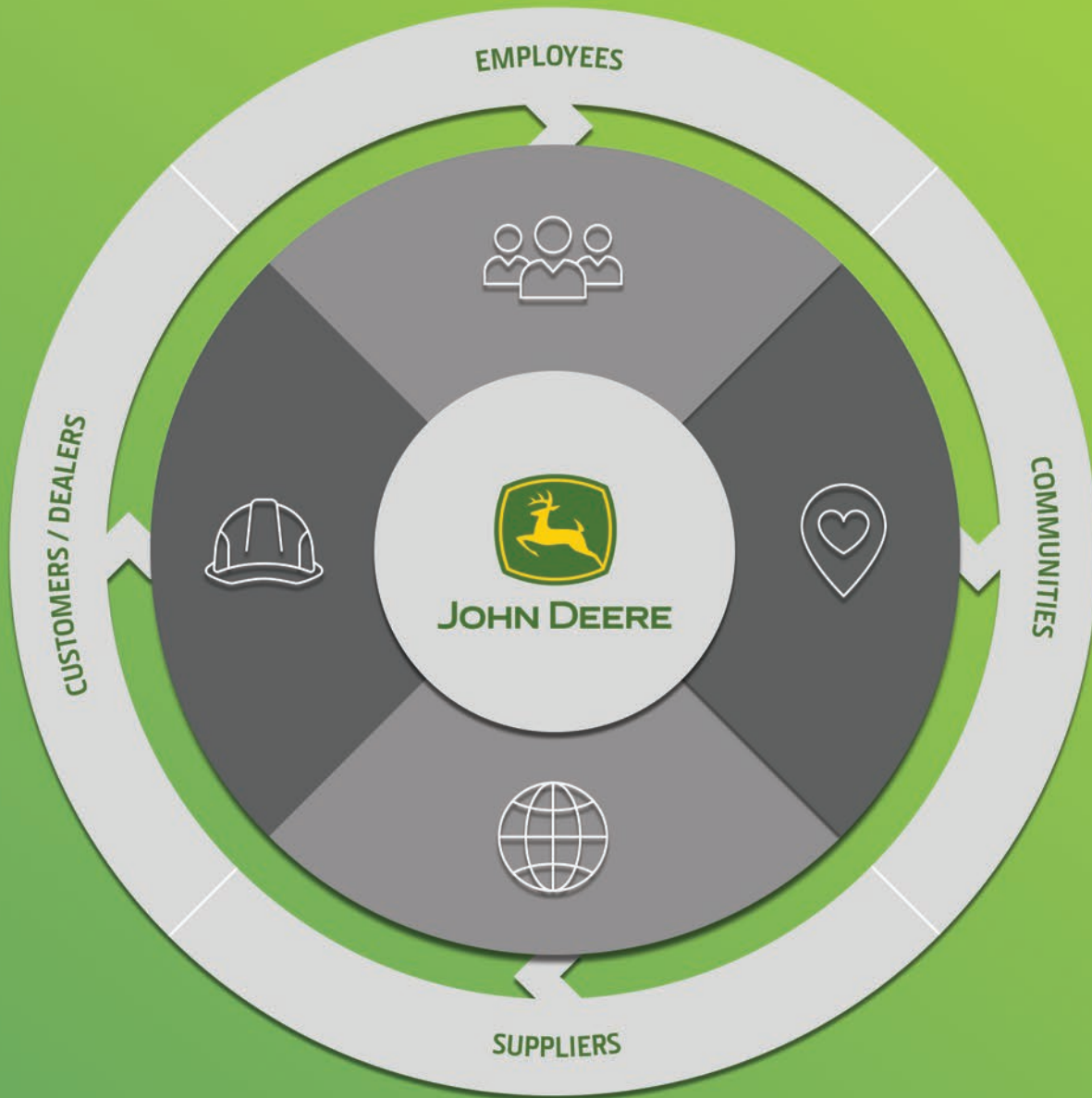

## DEERE'S FRAMEWORK FOR A DIVERSE, EQUITABLE, AND INCLUSIVE FUTURE

At John Deere, a global team of diverse individuals delivers the most advanced products, technologies, and solutions to ensure the productivity, profitability, and sustainability of a diverse set of customers around the world. We are best positioned to understand and solve the needs of these customers when we foster a diverse, engaged workforce and a culture of inclusivity.

At Deere, we know that our actions impact more than 75,000 employees as well as a broad set of stakeholders who rely on us. Therefore, our diversity, equity, and inclusion (DEI) framework incorporates our broader sphere of influence including customers, dealers, employees, suppliers, and communities.

We must run together in order to leap forward.

# LEADING WITH A DEI MINDSET

Diversity, equity, and inclusion (DEI) are not only priorities, but a mindset at John Deere. And it is what drives us to work tirelessly to attract a broad mix of employees with differing gender, race, ethnicity, sexual orientation, gender identity, gender expression, expertise, geographic, and life experience backgrounds.

And we know our work is only just beginning when we are onboarding a new employee. We continue to develop programs that will enable all our employees to reach their highest potential throughout their careers. Our employees are our most valuable asset.

Diverse teams generate better ideas and make better decisions. DEI is embedded in our recruitment and employee-development processes, which leverage talent-attraction methods, technology, managers and cross-functional teams focused on diversity, and our Employee Resource Groups (ERG).

Our leadership sets a consistent and transparent tone on DEI. Leadership training focuses on building an inclusive environment, driving change, developing talent, modeling our values and culture, and empowering others.

To help managers with development and team building, we also gather feedback via an inclusion index as part of our Employee Experience Survey.

Starting in 2021, employees globally are taking part in a progressive learning plan that provides a series of microlearning courses that develop the DEI know-how of our employees in short, engaging segments. The current courses cover topics such as unconscious bias, psychological safety, and empathy, and look to educate and inspire employees to grow in their DEI know-how through the bite-sized learning.

We continue to further interweave DEI into all aspects of how we lead and do business. Regional DEI councils help build and support a diverse, equitable, and inclusive work environment.

Our company-sponsored ERGs are employee-run organizations formed around a common dimension of diversity, interest, education, or experience that affects the workplace. ERGs bring together individuals with shared interests, while serving as resources to our business. Their efforts address three key focus areas: employee development, community involvement, and business alignment.

We want the best teams, comprised of the best people, who are each an integral part of the best place to work — John Deere.



To see more of the story, visit <https://www.deere.com/en/ourcompany/sustainability/sustainability-report/educate-and-empower/>







# OPEN CONVERSATIONS HOPE TO EDUCATE, EMPOWER

When Leslee Hager, vice president of internal audit, talks about DEI at John Deere, she often references “square zero.” It’s a phrase, or marker, that describes the starting point in an employee’s personal journey toward educating themselves in understanding the differences inherent in all people, including race, ethnicity, disabilities, sexual orientation, gender, etc.

And understanding, she said, is the key to moving a company from attracting diverse talent to becoming a company that retains diverse talent. “As a company and organization, we did a good job of bringing in diverse talent, but we weren’t always connecting and creating the environment and the culture where people felt comfortable staying,” Hager said.

The John Deere Accounting & Finance organization had earned a reputation for being diligent in DEI, but during a late 2020 roundtable discussion, Hager recalled a tipping point that motivated the team to raise the bar. “We were told, ‘No, this is not enough,’” Hager said. “One of the leaders said, ‘We need to take big action and we need to make sure all our leaders are engaged.’”

That’s all the team needed to hear.

## ELEVATING THE PROCESS

The Accounting & Finance team has workstreams focused on career development, diversity in leadership, recruiting and early career, culture and engagement, DEI conversations, and — linking them all — inclusion and communication. Each workstream has employee champions who hold regular meetings and facilitate subgroups that meet more frequently to keep interaction topical, educational, and engaging.

The Accounting & Finance leaders also piloted the United Way’s “United for Equity” program — a 21-day challenge. The team utilized the program’s structure to keep the DEI conversation moving.

One item highlighted during the 21-day challenge was Amy Wilson and Nicole Shearer’s “Perspectives” blog. The blog, known for its positive and unflinching approach, began as a look at being a woman at Deere and immediately earned a following. It has since grown in inclusion, encompassing everything from gender, religion, culture, race, and dual-career dynamics.

Since its February 2021 launch, the blog has generated and gathered dozens of submissions and posts. Many of the real-life stories share career issues and personal encounters.

**“In almost every blog post we tried to include an action item because that’s ultimately the point,” Shearer, manager cash management, said. “We’re hoping that we can be a voice that encourages people to really think about something from a different perspective and then hopefully have the conversations, raise awareness, and, if it all goes well, change behaviors.”**

Shane Edwards, regional group controller for North America, leads the DEI conversations. His monthly meetings typically have more than 500 employee participants. “Conversations create understanding, understanding creates empathy, and empathy creates action,” Edwards said. “With that, I believe the more we really listen to each other, the more we will work together to create a truly inclusive environment across all the workstreams.”

The Finance Development Program (FDP) is another program that further supports the DEI movement within Accounting & Finance. In addition to the broad support provided to all FDP participants, the program pairs diverse new hires with a mentor and coach, and connects them to professional organizations like the National Association of Black Accountants.

## SEEING IMPACT

The process, planning, and passion are proving effective.

Three years ago, Deere noticed that the percentage of women in middle-to-upper-level Accounting & Finance roles did not reflect the percentage of women in lower-level positions. With focused efforts, the department made meaningful progress on building a pipeline of diverse talent for these middle- and upper-level positions and has seen the percentage of mid-career roles in the U.S. held by women increase.

With results like that, the team’s efforts haven’t gone unnoticed — in fact, the organization’s DEI educational model is currently being implemented by the Supply Management and the Global Law Services Group organizations.





## FACTORY LEADERSHIP'S MISSION LINKS COMPANY WITH COMMUNITY



When Becky Guinn, factory manager at John Deere's Waterloo Works, thinks about the responsibilities that come with running one of the company's most iconic facilities, she doesn't limit herself to the four walls that surround her. And she doesn't want her team to think that way either.

Guinn has been an energetic and effective advocate in recognizing what the area's largest employer can bring by way of addressing hunger, housing, economic growth, diversity, and workforce development. She's very clear in her expectations: You have two jobs with John Deere, one inside the factory and one outside the factory.

Guinn has "partnered" members of her leadership team with an outside nonprofit group — like Iowa Heartland Habitat for Humanity or the Northeast Iowa Food Bank — and helped strengthen that link between the area's largest employer and the identified areas of greatest need in the community. To add rigor to the plan, Guinn established a community relations manager position and formed the Waterloo Citizenship Leadership Council. It's all part of the "intentional presence" Guinn said is needed within John Deere's home communities.

Guinn took the factory's leadership role in September 2019, nearly a year after the financial website 24/7 Wall Street called Waterloo the worst city in America for Blacks to live. In her two-plus years in the role, her efforts haven't gone unnoticed.

"Never before have I worked with someone with as sincere intentions to use the influence and resources of their company to improve this community as Becky," Waterloo Mayor Quentin Hart said.

Despite the challenges brought on by a pandemic, Waterloo Works employees continued to remain active in the key areas of community engagement and worked collaboratively on plans to attract and retain top talent and make Waterloo a pipeline for diverse talent. Through the current reporting cycle, there has been a 32-percent increase in volunteerism over the previous year with a 6-percent increase from production employees.



To see more of the story, visit  
[deere.com/en/our-company/sustainability/  
sustainability-report/factory-leaderships-mission/](https://deere.com/en/our-company/sustainability/sustainability-report/factory-leaderships-mission/)



## SUPPLIER DIVERSITY FOCUS ALIGNS WITH HIGHER PURPOSE

At John Deere we believe we can improve our business while making a meaningful difference in our communities through responsible business practices. This includes fostering an equitable, diverse, and inclusive supply chain. This is why we launched a new supplier-diversity strategy in 2021.

Our new strategy strives to generate economic value and jobs by working with small and/or diverse suppliers, increase competition and reduce risk in our supply chain, and foster innovation and diversity of thought in our business and communities.

To achieve this, we have committed to achieve the following by 2025:

- Spend \$500 million with minority-owned businesses
- Spend \$1 billion with woman-owned businesses
- Actively grow our relationships with other disadvantaged business enterprises (DBEs), including those owned by veterans, members of the LGBTQ community, individuals with disabilities, small businesses, as well as businesses in historically underutilized business zones.

Our supply management organization is working toward these goals by actively growing our relationships with minority-owned and disadvantaged business enterprises, finding better ways to identify diverse suppliers, and developing a more equitable onboarding process to support a diverse and sustainable supply base.



## WOMEN OF IMPACT: CULTIVATING FEMALE LEADERSHIP AT DEALERSHIPS IN BRAZIL



Luiza Lisboa has been an employee of John Deere for 11 years. As a territory aftermarket business manager in Brazil, she helps John Deere dealers connect with their customers from the first day of ownership through the entire lifecycle of the equipment. As a female in a traditionally male-dominated industry, she noticed a pattern over time — she was often the only woman in the room.

Last year, Lisboa connected with fellow Deere employees Cecília Breda, business development and partnering manager, and Fabiana Franco, dealer development manager, who also felt concerned by this trend — specifically, the lack of women in leadership positions at dealerships. They partnered with and were ultimately sponsored by Assodeere, the Brazilian Association of John Deere Distributors, forming a team with Giovana Teixeira, Assodeere’s financial and sustainability director, and Rejane Hermann, its executive director. Together, they created “Women of Impact,” a working group with a mission to work with the John Deere Dealership Network in Brazil to develop an organizational culture and further new and

existing initiatives that allow for more space and support for women. The ultimate goal is to increase the number of women working within the dealership network in general and in management specifically. Women currently hold 22 percent of the total positions and 19 percent of leadership positions within the network.

**“Women of Impact” is gaining steam by gathering data, initiating conversations with dealer leadership, and planning future events, including a kickoff. “We’ve been trying to do this as organically as possible,” Lisboa said. “We feel dealers want to own this journey, not because John Deere says it’s important, but because they understand that it contributes to their sustainability.”**



## PRIORITIZING OUR PEOPLE

### TALENT ATTRACTION AND RETENTION

As our company evolves, our workforce needs and recruiting strategy must evolve. Competing in today's market and advancing our Smart Industrial journey requires more deep and diverse technical expertise at all levels to drive innovation and solutions. We recruit at colleges and universities where John Deere has attracted talent for many generations, as well as at institutions where we have developed newer partnerships. This multidimensional approach ensures we are accessing the broadest and brightest talent.

To connect with diverse student populations, John Deere has been investing in diverse college and university students and their schools for many years. For example, to engage more diverse technical talent, this year we collaborated with the Society of Asian Scientists and Engineers by attending their virtual conference and socializing available career opportunities with John Deere. We have had great success building a pipeline of diverse talent from these types of programs.

Professional organizations remain a key tool in our recruiting process. While we have historically engaged with professional organizations primarily for early talent recruitment, this year we also focused on creating more synergies and opportunities to engage with professional organizations to socialize our mid-career opportunities. We moved to a more regionalized approach, versus purely engaging at large-scale conferences, to develop deeper relationships and opportunities to identify and recruit diverse talent.

We are also utilizing technology and process improvements to further enhance our recruiting outcomes. In 2021, we partnered to implement two uniquely designed Recruiting Process Outsourcing (RPOs) models focused on quality, speed, and diversity. These RPOs enable us to proactively identify potential talent. For example, adding baselines for diverse candidate panels and removing some burdensome administrative processes allows us to have greater speed in the market and an articulated focus on diversity. Technology-driven solutions like Job Analyzer and Eightfold, both Artificial Intelligence tools, afford us the opportunity to remove gender bias in job descriptions and anonymize résumés when building potential talent profiles.

We have intentionally built data transparency into our processes. Our Talent Acquisition (TA) dashboard drives accountability through every stage in the process — from diverse candidate panels to diverse interview slates, and ultimately an overarching focus on driving diverse talent throughout our employee population. Because there is visibility in the process, our TA team can partner with the business on the best approach to enhance the outcomes.

To attract and retain the best talent, we strive to offer some of the most competitive pay and benefits in our industry and the markets in which we operate. Benefits are tailored to each specific market and aim to provide resources that make sense for both the company and its employees. We are continually looking at new opportunities to enhance the benefits offered to our

employees and made substantial changes to the pay and benefits of both our wage and salaried workforce in 2021.

Additionally, after almost two years of seeing our employees adapt and continue to successfully deliver value through the dynamic environment that COVID-19 has created, we further embraced our flexible work policy this year. Additional enhanced benefits offered to most of our salaried and production employees this year included: enhanced free counseling service options, improved parental leave paid time-off benefits for both new mothers and new fathers, and expanded voluntary benefit offerings.

To maintain insights into the engagement and overall experience of our global employees throughout the course of their careers with John Deere, we periodically conduct confidential employee-experience surveys across most of the business. In these surveys, we emphasize employee engagement and manager effectiveness to ensure that we learn the extent to which employees feel engaged and supported in their work. Employees are strongly encouraged to participate, and we use results from the surveys to develop action plans across the enterprise. In 2021, we conducted more limited-scope pulse surveys to measure employee perceptions following our Smart Industrial transition. Focus was placed on the areas of empowerment, accountability, inclusion, and engagement. Survey responses are being used to understand what is going well, what needs to be improved, and how John Deere can be an even better place to work.

## BEST-IN-INDUSTRY BENEFITS: INVESTING IN OUR EMPLOYEES' FUTURES

In the fall of 2021, following a five-week work stoppage, Deere successfully negotiated a new six-year labor agreement with the International Union, United Automobile, Aerospace and Agricultural Implement Workers of America (UAW) covering approximately 10,000 employees across several U.S. facilities. The collective bargaining agreement builds on Deere's legacy of best-in-industry wages and benefits including profit sharing, active health care, cost-of-living adjustments to protect wage gains, as well as a company-funded defined benefit pension plan and defined contribution plan (401k) to enhance retirement flexibility and security.<sup>1</sup>

The agreement represents an additional investment of over \$3.5 billion in our employees. By providing financial progress to our employees and, by extension, our home communities, Deere will be better equipped to meet the challenges of the future and build products that transform lives and livelihoods around the world.

To recognize the significant performance and contributions of company's global salaried workforce, in November 2021, Deere announced pay increases for nearly all salaried employees. In addition, Deere continued to embrace a future of work involving flexible and remote

## TALENT DEVELOPMENT

We strive to enable our employees to reach their highest potential by creating purpose-driven work opportunities, unique learning experiences, professional and personal development opportunities, comprehensive performance reviews and development plans, and mentoring opportunities.

For employees who join John Deere right out of college, the John Deere Development Program is a robust rotational program that provides early career employees with diverse experiences and a broad network to lay the foundation for their careers. New hires rotate between two or more entry-level roles within their fields of study to build knowledge and experience. Development programs exist for engineering, information technology, supply management, marketing, analytics, accounting and finance, and human resources.



opportunities based on the idea that employees can deliver value to customers everywhere if they are empowered to create value from anywhere. These policies will help Deere access new, diverse talent pools.<sup>2</sup>

<sup>1</sup>While our UAW contract negotiations began during our fiscal year 2021, the contract was ratified in November 2021, which is part of Deere & Company's fiscal year 2022.

<sup>2</sup>Changes to salaried workforce pay and benefits were effective November 1, 2021, which is part of Deere & Company's fiscal year 2022. Deere & Company's enhanced flexible work policy was announced in November 2021, which is during Deere & Company's fiscal year 2022.

As employees grow throughout their careers, we are committed to offering experiences and opportunities that will challenge and reward them. To support these efforts internally, we offer functional and leadership learning tools and invest in targeted development for both people and technical leaders.

Externally, we provide employees at all levels opportunities to continue their formal education and acquire the critical skills necessary to meet future challenges through the Tuition Repayment Plan that reimburses 100 percent of the cost for tuition and books. Whether an employee decides that they will be a people leader or a technical leader, we provide development, training, and experiences.

Under the “Technical Path,” leaders develop as subject matter experts and contribute their technical and professional skills to enable John Deere to fulfill our higher purpose. Through their training and skills, these leaders execute, support, research, and innovate in their areas of expertise as they develop and teach others. We draw on their knowledge to drive innovation, continuous improvement, and the development and execution of the John Deere Strategy. The John Deere Fellows Program is the highest level of recognition for employees who have contributed to the company’s success through deep expertise in their functional areas.

Under the “People Path,” leaders are developed through functional and leadership-development experiences, exposure, education, and evaluation to maximize their potential to achieve outstanding business results. Our Smart Industrial operating model leverages a Leadership Model that requires our leaders to demonstrate several key capabilities connected to our values and history, while guiding us into the future.

The new leadership model highlights the behaviors expected of John Deere leaders as they execute our strategy, model our culture, and create our future. These future-focused expectations were adapted for leaders and contributors at all levels and added to an enhanced Global Performance Management system, which will launch in 2022. Now, employees will have clear expectations for what will be delivered for our “business objectives” and how we will deliver them.

# HACKATHONS

## HIGHLIGHT DEERE’S INCLUSION, RECRUITING POWER, AND INGENUITY

John Deere uses the power of hackathons to drive innovation, collaboration, and empowerment. The company also believes in involving employees from legal, accounting, marketing, and operations to create an inclusive mix of all ideas. By doing so, hackathons allow John Deere to match problems with creative solutions. “The basic premise,” Josh Carson, senior staff engineer at John Deere’s ISG-Urbandale, said, “is getting shared time for many people to open up doors and make something more awesome.” While that “more awesome” may be a new product or a new process, it’s really a culture that makes hackathons a success. By stressing their importance, senior leadership has made hackathons a valued priority in employees’ training and development. This focus increases participation, which has been aided by a virtual, global connection.

Sometimes industry-changing products are an end result. During a 2018 hackathon, product marketing colleagues and Ray Liu, guidance engineer for autonomy, each set out to solve a problem involving inefficiencies during harvest. Curtis Maeder, systems engineer, noticed that both parties were each approaching the same project from different angles and encouraged the forming of one team. Roughly six weeks later, a working prototype was moving through the field. From there AutoPath™ software — a revolutionary technology that helps farmers collect data from the first pass in the field to establish row guidance for all subsequent field passes — was born. Having real-world examples to point to helps employees see the value in hackathons and helps to tell the John Deere story. Carson said when it comes to recruiting, hackathons position the company as a technology leader in the manufacturing world and a technology player in the innovation field.



To see more of the story, visit [deere.com/en/our-company/sustainability/sustainability-report/hackathon/](https://deere.com/en/our-company/sustainability/sustainability-report/hackathon/)



# DEALERSHIP TALENT

John Deere dealer technicians play a critical role in keeping customers' machines up and running, enabling the unmatched support that the our dealer network provides. These roles are in high demand, with expected job growth for service technicians and heavy mechanics outpacing general job growth. To promote interest in the service technician career path, John Deere partners across the globe with our dealers and numerous organizations to drive interest in these high-quality jobs.

Two examples of these programs are the John Deere TECH Program and the Military Career Skills Program in the U.S. The John Deere TECH Program is a two-year Associate Degree Technician Training Program that combines classroom, lab, and on-the-job training to provide students with the skill sets needed to develop into full-time John Deere technicians. Today there are over 20 John Deere tech locations across the U.S. and Canada where John Deere and dealers provide support through scholarships, paid internships, tools, training, and advertising, among other things.

John Deere is passionate about finding a way to give back to those who have served our nation. The Military Career Skills Program is one of the ways we support service members as they transition to a civilian career. John Deere supports educating service members on this potential career path, and then helps with job placement, internships, and free training. This program helps service members build their résumés while gaining knowledge of the agriculture and construction industries.

Through these programs and others like it, John Deere and our dealers are playing a critical role in driving interest and job growth in this career path.



SOCIAL

## RECRUITMENT OF MILITARY VETERANS HELPS DEALERSHIPS

Starting any new program comes with a basic set of challenges. Starting one at the onset of a global pandemic? Well, you'd better have a really good concept. Luckily for John Deere's Military Career Skills Program, that's exactly what they had.

The U.S.-based program has one goal — connect military veterans with technician jobs at John Deere's network of independent dealers. David Bostic, the company's service development manager, said there are two ways to make that happen — either through direct hiring based on his recruiting efforts at military career fairs or through the Department of Defense's SkillBridge internship program.

As a Deere employee, Bostic networks between military personnel and John Deere dealerships. In 2021, John Deere independent dealerships hired 119 military veterans into technician jobs who have come through the Military Career Skills Program, helping lessen the stress many dealers experience in filling the much-needed roles. Of the 119, 81 were direct hires and 38 started as interns and then were hired full-time by the dealership. Ninety-three percent of all interns brought into the program get a job offer from their dealers and the retention rate of the interns is about 86 percent.

With nearly 3,000 John Deere dealer locations in the U.S., Bostic said there is an annual need — and company target — of training and developing 1,000 service technician candidates each year. John Deere TECH, a company-sponsored program offered at 24 colleges throughout the U.S. and Canada, accounts for about 300 dealership technician job placements annually.

Bostic said what separates Deere from other employers recruiting veteran service members for internships is the company's job-placement assistance post-internship, immediate training opportunities (even available before the internship begins), and a 25-percent tool discount.

The training benefit is a big hook, Bostic said.

"That benefit kicks in the moment they contact us, and we get them set up in the program and in touch with dealers right away," he said. "They have access to classes on our site and this helps them prepare for any potential interview they would have with a dealership. They can tell them they've already taken John Deere classes and they can show their scores. It really prepares them for that next step."

John Deere Foundation's

# BOLD

## Commitment



Inspired by humanity's ability to overcome, in 2021, the John Deere Foundation pledged to invest at least \$200 million over the next 10 years in three groups of people: smallholder and resource-constrained farmers around the world, families and youth in John Deere's home communities, and the company's own workforce. In making this pledge, the foundation strengthened its commitment to the United Nations' Sustainable Development Goals by aligning its work with targets related to ending poverty, eliminating hunger, and ensuring quality education by 2030.

### FARMERS FIRST

At the heart of John Deere's higher purpose is our belief that farmers are essential to global prosperity. That is why the foundation has committed \$50 million to smallholder and resource-constrained farmers throughout the world to bolster their ability to make a living, feed a growing global population,

and reduce inequality. In 2021 alone, the foundation invested \$3.4 million in farmers around the world, reaching 1.4 million total farmers.

Guided by similar values, [One Acre Fund](#) empowers farmers in Africa by "putting farmers first." One Acre Fund provides farmers with resources and support fundamental to their success, including the financing of high-quality seeds and fertilizer, distribution of farm inputs, agricultural training, and commercialization opportunities. As a result of this work, incomes of One Acre Fund clients averaged 39-percent higher than control farmers on supported activities between 2018 and 2020.

When One Acre Fund started its work in 2006, it piloted its approach with 38 farmers in Kenya. By focusing its efforts on making its model more effective, One Acre Fund has grown to directly serve over 1.4 million farm families in seven African countries. In 2019, the foundation committed \$5 million over five years to One Acre Fund, making it the largest corporate foundation gift in the organization's history and one of the largest grants in the John Deere Foundation's history.





## OUR NEIGHBORS

John Deere's success over an almost 200-year period is inextricably linked to the prosperity of the families and youth who live, learn, and work in our home communities. That is why the foundation has committed \$100 million to ensure inclusive and equitable access to resources and educational opportunities critical for human dignity and self-sufficiency within these spaces.

Perhaps there was no greater aftershock from COVID-19 in our home communities than the dramatic increase in food insecurity, a particular threat to households with children, Black and Hispanic families, and those fighting against poverty.

[River Bend Food Bank, a nonprofit organization serving 23 counties in Western Illinois and Eastern Iowa](#), was able to meet these needs by distributing over 20 million meals in 2021. In 2021, the foundation pledged \$1.7 million to River Bend in an effort to end hunger in John Deere's headquarters region.

In total, the foundation invested \$2.7 million in food-banking systems around the world in 2021, supporting the distribution of nearly 12.8 million meals. In our U.S. home communities alone, this investment produced almost 10.4 million meals, the equivalent of \$32 million in economic relief (calculated using U.S. food sales data).

## PUTTING OUR BACK INTO IT

While the company is known for its industry-leading products, its people help make, shape, and enrich the communities where they live and work. The foundation's goal is to engage each employee by committing \$50 million over the next 10 years to further mobilize their vast talents and generosity. In line with this commitment, almost \$4.8 million was donated in 2021.

For example, in 2021, more than 70 Waterloo Works production and maintenance employees volunteered to build the walls for six homes in [Iowa Heartland Habitat for Humanity](#) communities. In total, they built over 200 walls inside the John Deere facility. Once the walls were complete, they were set and sided by more John Deere employees at multiple home-construction sites.

In 2021, John Deere employees recorded over 124,000 volunteer hours. 111,000 of these hours were logged in the U.S., where the latest estimated value of each volunteer hour is \$28.54. This means John Deere employees created over \$3 million of additional value in their service of others.



HOW ARE WE ADVANCING LIVES AND LIVELIHOODS?

# \$42.5M

*invested in communities  
around the world*



## \$2.7M

### Invested in Food-Banking Systems

This served 12.8 million meals in 2021, which equates to over \$32 million in economic relief to those most vulnerable in our home communities (calculated using U.S. food sales data).



## \$3.4M

### Invested in Farmers

1.4 million total farmers were reached



## 124,000

### Volunteer Hours

111,000 of these hours were logged in the U.S., where the latest estimated value of volunteer time in the U.S. is \$28.54 per hour. This means John Deere employees created over \$3 million of additional value within U.S.-based communities.



## WORKPLACE HEALTH & SAFETY

At John Deere, the health and safety of employees is our number-one priority, and our goal is to achieve safety excellence through increased focus on health- and safety-management systems, leading indicators, risk reduction, and prevention.

Our safety-balanced scorecard includes leading and lagging indicators and is designed to drive continuous improvement. All in-scope units are utilizing the scorecard and greater than 75 percent are achieving their targeted levels of performance.

Today, reducing ergonomic risk is our largest opportunity to prevent injuries in the workplace. We are committed to reducing these injuries by further integrating ergonomic principles and practices into our product design and manufacturing processes.

In 2021, we established standard ergonomics program requirements and performed self-assessments at all manufacturing units<sup>1</sup> and large parts distribution centers. We integrated a “Prevention Through Design” initiative during two new product introductions. The goal of the initiative was to identify and mitigate safety and ergonomic risks during the design of the product and associated manufacturing processes.

Finally, we have continued a sharp focus on preventing potentially serious incidents (PSIs). These events require a full investigation, standardized reporting, and sharing across the enterprise. PSIs associated with material movement are a priority. Several units across the enterprise have been deploying best-in-class technology solutions to reduce the risks associated with pedestrian and fork-truck interaction.

Our commitment to the health, safety, and well-being of our employees goes beyond the workplace. We are mindful of the overall well-being of employees at home and in our communities. We provide targeted programs in the areas of financial, physical, emotional, and social well-being to our employees and their families.

To demonstrate our continued commitment to our employees’ health and safety, we have challenged ourselves again as part of our new Leap Ambitions. Starting with 2021 as our baseline, we are committed to achieving a 20-percent reduction in our Total Recordable Incident Rate by 2026.

<sup>1</sup>Excluding recent acquisitions.



### Continuous Improvement Keeps Employees Safe and Grounded

John Deere Des Moines Works production employees on the factory’s cotton picker assembly line utilized the company’s Continuous Improvement process to redesign how five assemblers addressed working at various heights to install trash ducts, water lines, and fuel and water tanks. By creating an innovative cab-platform work center, the assembly processes were lowered by telescoping lifting columns, allowing workers to remain on the ground.



To see more of the story, visit [deere.com/en/our-company/sustainability/sustainability-report/continuous-improvement/](https://deere.com/en/our-company/sustainability/sustainability-report/continuous-improvement/)



## PRODUCT QUALITY

Quality is a core value for John Deere. Our success with our Distinctive Product Quality initiatives has ensured that our customers' uptime needs are met to keep them running. Product quality at John Deere has four primary focus areas:

### PRODUCT DEVELOPMENT QUALITY

During product development, John Deere's quality processes include significant reliability and durability testing, validation of new parts and procedures, and tracking to ensure products are ready for our customers at launch. Cross-functional teams, including both internal disciplines and critical suppliers, track results, adjust as needed, and manage programs to make sure customer expectations are met throughout the product lifecycle.

### MANUFACTURED QUALITY

Quality processes, audit checks, and automated controls are built into each station of operation. Teams also validate and audit the final product using a customer-focused machine runoff, final set of inspections, and smart testing tools that allow them to proactively find and address any issues prior to product shipment.

### PROBLEM RESOLUTION

When problems or issues are identified, we follow a rigorous problem-resolution process. This ensures we address issues quickly and completely by finding the root cause, validating solutions, and resolving problems with preventive actions. Leveraging virtual validation and lab analysis tools helps us quickly find a solution and make improvements. Access to data and information about connected machine performance and from our production facilities helps us more rapidly identify and resolve customer problems.

### CUSTOMER SATISFACTION

Leveraging customer insights and experiences helps us deliver Distinctive Quality by targeting quality levels for each product that are unique in the industry. We closely track performance of all products in relation to quality goals. We regularly follow up with our customers to ensure our products meet their specific requirements. Customer feedback drives modifications to our processes and product improvement, for example, improving longer-term reliability and durability well after the manufacturer's warranty has expired.

John Deere has invested over \$35 million in quality worldwide by improving our existing dimensional measurement resources through laboratory renovations and state-of-the-art equipment updates. As our product size, complexity, and precision increase, the demand on our measurement tools used to ensure product quality varies greatly and continues to rise. These updates are in support of product quality, the Smart Industrial operating model, and the safeguarding of our customers.

# PRODUCT SAFETY

Our Corporate Product Safety Department works with factory safety committees, especially during product technology development, and provides coordination and consistent processes for multiple-factory product-development projects. Product safety and standards engineers keep abreast of, and lead advancements in, product safety by participating in standards development and trade organizations.

During all product design, we adhere to our General Rule for Product Safety. This rule requires that an acceptable design must not present an unreasonable risk of injury to a product user or others nearby. In applying this rule, we consider the people, environmental conditions, and other products with which a product is likely to be involved.

Beyond our General Rule for Product Safety, we rely heavily on applicable safety standards as published by the International Standards Organization (ISO), the American National Standards Institute (ANSI), the American Society of Agricultural and Biological Engineers (ASABE), the European Committee for Standardization (CEN), and other organizations. Our goal is to meet or surpass the intent of these standards.

As part of our design process, we ensure safety information appears in pre-delivery instructions, operator's manuals, technical manuals, and other service publications according to the activities to which they apply. In addition, safety instructions in the form of safety signs are affixed to the product to appropriately warn an operator of potential hazards.

We also provide training resources such as videos, posters, brochures, and guides. We support child-safety organizations, such as Progressive Ag Safety Day, and we encourage our dealers to promote safety in their communities.

We have a robust incident-reporting system that collects incident information involving John Deere equipment from numerous sources, including our dealers, the customer call center, and public information. All incident reports are forwarded to the Corporate Product Safety Department and entered into a central repository. A formal report of the incident is sent to the factory and marketing groups responsible for the product, where it is reviewed by the factory product safety committee.

We have developed and use product-repair and -recall processes, which include specific activities and procedures for product-recall reporting and notification. All consumer product recalls are posted on the John Deere website and the website of the appropriate governmental agency.

## Folding Handrails Serve Two Purposes in One Idea

Function and safety are key priorities for John Deere, especially when designing equipment. One recent example involves the John Deere AB485 Air Boom Dry Fertilizer Spreader, which is factory installed on Deere's F4365 large-scale nutrient-applicator system.

The AB485 has hoppers — or bins — on top of the machine that are filled with dry fertilizer for application in the field. To fill the bins and clean the machine, customers needed a safe-access mechanism that did not require climbing over a tarp structure that protects against water intrusion.

In a true tale of safety meeting function, two design challenges were solved with one clever component: folding handrails.

The ingenious system serves a dual purpose. First, it folds up to provide handrails for the customer when they are accessing the top of the machine. And, when folded down, it creates the structure for the tarp to wrap over.

The cross-functional team's solution was the first in the industry and reinforces John Deere's leadership in product safety.

The key innovation is the ability to combine a safety feature with a functional one. By using a keen eye, designers were able to accommodate both the spacing needs on the tarp system with the requirements for handholds.

In the end it serves as an example, and reminder, that customers don't have to give up convenience for safety.





**GOVERNANCE**

# CORPORATE GOVERNANCE

At John Deere, we believe strong corporate governance — starting with our Board of Directors — enhances our business. With our Board’s oversight, we conduct business openly, honestly, and fairly. We measure our accomplishments by how we achieve them as well as by the results themselves. More than this, we know that our results will be greater and more long-lasting when we achieve them the right way. In short, we believe that strong corporate governance creates long-term shareholder value.

John Deere currently has a board of 12 directors.<sup>1</sup> Directors are nominated based on their skills, experiences, backgrounds and the needs of the Board and our company. Every Director must stand for election annually.

At all times, a majority of the Board of Directors must meet the criteria for independence established by applicable laws and regulations and the New York Stock

Exchange. At the end of calendar year 2021, all of our Directors, except our Chairman, were independent.

Directors are recruited to strengthen the Board’s diversity and ensure that the Board reflects and understands the diverse perspectives of John Deere’s stakeholders around the globe. Four of our 11 independent Directors are female and three are people of color.

Our Presiding Director is elected by a majority of the independent Directors. Among other duties and responsibilities, the Presiding Director presides at all meetings of the Board at which the Chairman is not present and, jointly with the Chairman, approves the schedule of Board meetings, the proposed agendas, and the materials to be sent to the Board. The Presiding Director can also call meetings of the independent Directors and is available for direct communication with shareholders.

<sup>1</sup>As of November 1, 2021, the first day of Deere’s fiscal year 2022, Leanne G. Caret was elected to the Deere & Company Board of Directors. This temporarily raises the number of Deere’s Directors to 12. Dipak C. Jain is not standing for re-election at the Deere & Company 2022 Annual Shareholder Meeting on February 23, 2022. Therefore, it is anticipated that the number of Directors will return to 11 following the 2022 Annual Shareholder Meeting. All metrics in this report are calculated on the basis of the 12-member Board of Directors reflected here.



From left to right, top to bottom: Dipak C. Jain, Clayton M. Jones, Tami A. Erwin, Gregory R. Page, Leanne G. Caret, Alan C. Heuberger, Sherry M. Smith, Dmitri L. Stockton, Charles O. Holliday Jr., John C. May, Sheila G. Talton, and Michael O. Johanns.

# SUSTAINABILITY GOVERNANCE

The Deere & Company Board of Directors has oversight of sustainability and is responsible for aligning our strategic priorities as well as ensuring Environmental, Social, and Governance (ESG) principles are integrated throughout the enterprise. The Corporate Governance Committee reviews ESG topics on a quarterly basis. During 2021, the committee was briefed on our strategic sustainability initiatives, goal-setting process, performance on metrics and targets, sustainability reporting roadmap, feedback from stakeholder engagement, and the landscape of shifting ESG expectations and practices. The committee also received educational updates from external experts on evolving trends and best practices in ESG reporting. Through regular engagement, the committee guides and directs our strategic ESG planning, ESG goal setting, and scope of our sustainability reporting.

The compensation committee is responsible for ensuring that compensation is aligned with the strategic priorities, performance, and opportunities of the company. Throughout 2021, the committee was involved in understanding our progress toward setting the Leap Ambitions and the priorities that will move our business forward over the next decade.

In addition, the full Board of Directors has oversight of the risks and opportunities associated with climate change. Updates are provided in alignment with our Enterprise Risk Management process. Additional detail regarding their role and our governance of climate change can be found in our Task Force on Climate-related Financial Disclosures (TCFD) Report.

To enable and execute on these initiatives, a variety of teams and policies are in place to ensure the full organization is aligned to deliver on our ESG priorities. With the Smart Industrial operating model now in place, sustainability is further driven throughout the organization and has altered some of our internal structure around delivery of ESG.





### **CEO STAFF**

John Deere's CEO Staff provides direction for and ultimately owns the execution of our sustainability initiatives. Oversight and ownership at this level ensures that our sustainability initiatives are aligned with and a core component of our overall business strategy. CEO Staff receives updates from the sustainability teams throughout the year. During 2021, these updates encompassed the following topics: Scope 3 greenhouse gas emissions quantification and Science Based Targets initiative-based goals; goal-setting priorities; performance on 2022 targets and metrics; status updates on projects and initiatives enabling our ESG priorities; sustainability reporting trends and multiyear roadmap; and stakeholder feedback.

### **SUSTAINABILITY LEADERSHIP TEAM**

The Sustainability Leadership Team is comprised of a group of leaders from our Environmental, Health & Safety, Production Systems, Technology, and Finance organizations. This team engages closely with the teams working on setting strategic ESG priorities, driving toward delivery of our sustainability goals, and determining the roadmap for effective reporting. The group also works to engage with other leaders across the company to ensure alignment of our strategic ESG priorities with our business objectives, technology roadmap, and financial performance.

### **GOAL CHAMPIONS**

Each of our sustainability-related goals has a Goal Champion. Each Goal Champion has ownership of the delivery of that goal and is responsible for aligning priorities and resources throughout the organization,

reviewing progress and challenges, and driving execution of initiatives to meet the goals.

### **CLIMATE TEAM**

During 2021, we established a Climate Team within the organization, which is comprised of a cross-functional team whose roles are responsible for action related to the various risks and opportunities that we have identified for our business related to climate change. This team monitors developments, quantifies risk and opportunities, develops action plans, and engages throughout the organization to ensure alignment and assess performance toward our goals and targets. Members of this team engaged in a variety of projects this year, including quantifying our Scope 3 GHG emissions, setting science-based targets, executing a Carbon Market Pilot program with customers, and external engagement on policy and industry trends.

### **SUBJECT MATTER EXPERTS**

Our broad team of Subject Matter Experts are the individuals who are critical to execution of our priorities. Working with their teams, they develop the implementation plans for achieving our sustainability initiatives. They continually monitor and engage these teams to ensure we are delivering on those action plans. They also serve a key role in keeping the rest of the organization informed on progress and roadblocks as they track and report metrics on a regular basis. These individuals have deep technical knowledge in their respective areas of expertise and serve as the go-to within the organization for their area.



# CYBERSECURITY AND DATA PRIVACY

At John Deere, we have seen a dramatic increase in the amount of data that is produced, collected, and analyzed. Properly managing and processing this data allows us to better run our enterprise, provide enhanced customer support, and offer better, more productive products and services for our customers.

Because of the importance of cybersecurity and data privacy, the Corporate Governance Committee and Audit Review Committee provide Board oversight. To ensure strong execution and engagement with the Board, we have established a Digital Risk Governance Council and an Executive Business Conduct Council, which provide senior leadership oversight of information security governance, data governance, digital risk management, and privacy.

We leverage the National Institute of Standards and Technology Cybersecurity Framework as the foundational building block of our global information security program. Our program focuses on assuring operational resilience and protecting the information that has been entrusted to us by our customers, employees, dealers, and suppliers, as well as the data created by the enterprise. Learn more about our Digital Security program [here](#).

Our data privacy program is constantly monitoring, adapting to, and working diligently to comply with changes in global privacy legislation. While the European General Data Protection Regulation and other regional and state regulations have brought increased requirements and more general awareness to privacy, we have long been focused on ensuring responsible use of personal data.

John Deere maintains its European Binding Corporate Rules, which are often considered the gold standard in the European Union for the transfer and processing of personal data. To accomplish this, we routinely submit significant parts of our privacy program for review by European regulators.

We continue to provide a safe and secure environment for our customers to collaborate with their trusted advisers. With over 260 companies on our Application Programming Interface (API) platform at the end of fiscal year 2021, customers choose who they share data with, which they can easily check at the John Deere Operations Center.

# SUPPLY CHAIN MANAGEMENT

John Deere relies on global suppliers to help keep our customers up and running. Specifically, we have committed to growing our diverse supply base. In 2021, we expanded our supply base of small woman-owned businesses by 175 percent to nearly \$4 million while also expanding small disadvantaged (minority-owned) suppliers by over 200 percent to over \$14 million in spend. Looking ahead, our Supplier Diversity Program aspires to source \$1.5 billion with diverse businesses by 2025.

As we continue to develop our supply base, our suppliers are expected to follow our Supplier Code of Conduct, which ensures our suppliers conduct business with integrity and in a socially and environmentally responsible manner. For additional information regarding critical materials and how we manage the risks associated with those materials, please refer to the SASB Index.

In addition to managing the diversity of the supply base, the company is continually assessing and working to improve our suppliers' performance. This includes anything from compliance to financial health. A corrective-action process provides our suppliers opportunities to continually improve. In 2021, we continued to engage EcoVadis, a recognized global leader in corporate social responsibility and sustainability ratings, to assess the sustainability performance of key suppliers. Over 900 logistics, direct material, and indirect material and services suppliers have been asked to complete the sustainability assessment. Plans are to reach over 1,000 suppliers by the end of fiscal year 2022, which will encompass over 60 percent of our total material spend.

John Deere's Achieving Excellence program acknowledges suppliers whose quality, delivery, cost management, wavelength, and technical support surpass expectations. The Achieving Excellence program also incorporates sustainability initiatives.



## New Supplier Award Keeps Attention on Sustainability

In launching its Supplier Sustainability Award program, John Deere has put additional emphasis on the topic of environment as well as the overall lives and livelihoods of our customers and dealer network. The program raises supplier awareness of the importance of sustainability.

In late 2021, the company invited all global suppliers to participate and tell their success stories as defined by three categories: People and Environment Impact, Business Impact, and Customer Impact. The categories cover topics ranging from social responsibility, environmental stewardship, regulatory and risk reduction, and value improvement for our customers.

The awards program will honor submissions from each of John Deere's four global business regions in early 2022. The annual award looks to drive innovation that improves the overall sustainability of our value chain, recognize suppliers who have delivered meaningful impact, and ultimately enable solutions that are better for our customers.



# COMPLIANCE

Operating with the highest business ethics requires vigilance. The John Deere Center for Global Business Conduct helps ensure consistent compliance with increasingly complex global laws and regulations in a dynamic global business environment.

The Center for Global Business Conduct provides continuous training, communications, and best practices throughout John Deere's operations to sustain our strong ethical culture and ensure compliance with laws and regulations. Our Code of Business Conduct was refreshed in 2021, with a focus on providing simple, easy-to-use guidance on employee expectations in an engaging and useful format reflecting our full global enterprise. The Code provides direct access to our global policies and offers guidance on complex and sometimes ambiguous business and cultural situations.

In parallel with the Code refresh, we refreshed several of our global ethics and compliance policies which further outline expectations for employee behavior. We paid particular attention to enhancing our policy related to harassment and discrimination, along with a set of trainings on how we treat each other and work together, and a series of communications providing guidance on navigating the hybrid work environment. We continued to invest time and resources on our anti-bribery and anti-corruption program, including communication, training, and process enhancements.

Ethics and compliance training is required for full-time salaried employees at least four times per year, and new salaried employees must complete a core curriculum of training courses. Training topics focus on key compliance risks and expectations for employees.

Outreach to employees is a critical element of our compliance program, especially for compliance team members embedded in key geographies. We make a

concerted effort to connect with employees around the world through our compliance networks and Employee Resource Groups.

Our ethical culture is a source of pride among our workforce. We measure our culture using questions embedded in our Employee Experience Survey, new hire surveys, and exit surveys. Ethics-related survey items consistently rank among our top-scoring items around the globe.

Strong governance starts with our Board of Directors and is built upon robust processes and rigorous audits. We rely on our employees and other stakeholders freely reporting concerns of actual or potential misconduct or other risks. To encourage such reporting, we refreshed our reporting and non-retaliation policies to more clearly express how and when employees should report concerns and reiterate the company's commitment to non-retaliation. The John Deere Compliance Hotline is operated by an independent company and is available to receive confidential reports from anyone within or outside the company. To access country-specific Hotline information, employees can view the posters on display at each company location or visit the John Deere intranet. The John Deere Compliance Hotline website is listed in the Code of Business Conduct and the Supplier Code of Conduct.

We address all Hotline reports thoroughly and promptly. John Deere will not tolerate retaliation against any individual for making a report or participating in an interview or investigation. This is true even if an investigation does not uncover any actual misconduct.

# HUMAN RIGHTS

At John Deere, we honor human rights and respect the individual dignity of all people globally. Our commitment to human rights requires that we understand and carry out our responsibilities consistent with company values and practices.

We strive to ensure that human rights are upheld for our employees and all workers in our supply chain. Our commitment to respecting human rights is defined in our Code of Business Conduct, Supplier Code of Conduct, Dealer Code of Conduct, and John Deere's Support of Human Rights in Our Business Practices, which establish clear guidelines for our employees and suppliers, while helping to inform our business decisions.

John Deere employees have a responsibility to uphold the standards of honor and integrity in the Code of Business Conduct. All employees are required to review the code and incorporate it into their work and behavior. To foster a more positive workplace, the code provides guidance on creating an inclusive environment that promotes mutual respect and acceptance. It also discusses how

to maintain a high level of integrity when working with customers and suppliers.

When choosing suppliers, we engage with those who comply with laws and uphold values aligned with our own. Our employees regularly discuss the Supplier Code of Conduct with suppliers, and most supplier contracts require adherence to the Supplier Code of Conduct. This code addresses the following key areas: labor and human rights, health and safety, environment, and ethics.

As the face of the John Deere brand to our customers, our dealers, distributors, and their sub-dealers (collectively, dealers) must be committed to conducting business ethically and in compliance with all applicable laws. To ensure that dealers conduct business with a high degree of integrity and in a socially and environmentally responsible manner, John Deere asks and expects all dealers to adhere to the Dealer Code of Conduct. Like the other codes, the Dealer Code of Conduct covers many topics ranging from labor, human rights, health and safety, environment, and ethics.



## JOHN DEERE POLICIES

Because we believe corporate governance is integral to creating long-term shareholder value, our Board of Directors has adopted company-wide corporate governance policies that are periodically reviewed and revised to ensure that they reflect the Board's corporate governance objectives. These policies, along with the John Deere Code of Business Conduct and other work-specific policies, establish the framework by which we conduct ourselves and our global business in full compliance with the law and by which we affirm our commitment to integrity in everything we do.

### CORPORATE GOVERNANCE POLICIES

These policies establish the guiding principles for John Deere corporate governance, including Board composition and functions, meetings, committees, compensation, and management evaluation and succession planning.

### CODE OF ETHICS

This code establishes ethical standards applicable to Directors, employees, and officers in satisfaction of applicable laws and regulations and the New York Stock Exchange.

### CODE OF BUSINESS CONDUCT

This code provides specific guidance to all employees and outlines how we can and must uphold and strengthen the standards of honor and integrity that have defined our company since our founding.

### DEALER CODE OF CONDUCT

This code requires that dealers conduct business with a high degree of integrity and in a socially and environmentally responsible manner.

### ENVIRONMENT, HEALTH, AND SAFETY POLICY

With a focus on continuous improvement, this policy provides that we conduct our business in a manner that protects our customers, employees, communities, suppliers, and the environment.

### GLOBAL CONFLICT MINERALS POLICY

This policy sets forth our commitment to conducting worldwide business operations in a manner that complies with applicable laws and regulations regarding conflict minerals.

### SUPPLIER CODE OF CONDUCT

This code requires that all our suppliers conduct business with a high degree of integrity and in a socially and environmentally responsible manner.

### SUPPORT OF HUMAN RIGHTS IN OUR BUSINESS PRACTICES

This guidance outlines how John Deere strives to ensure that human rights are upheld for our employees and all workers in our supply chain.

# POLITICAL ENGAGEMENT

At John Deere, we believe that participating in democratic political processes around the world and advocating for public policies that permit us to compete fairly and freely in the marketplace are vitally important to all our stakeholders. In whatever form it might take, our engagement in the political process is grounded in and guided by our firm commitment to strong corporate governance and global corporate citizenship. John Deere engages in public policy advocacy around the world to underscore the responsibility of a global business to participate in our communities. We engage in public policies such as trade, agricultural development, and regulations related to the impact of how John Deere operates around the world. We promote policies such as rural broadband, rapid adoption of precision technologies, mechanization, infrastructure, and tax and financing access that impacts our customers. As a part of these efforts, we engage with like-minded companies, NGOs, and associations as well as participate in public-private partnerships to reach global audiences and policy makers.

## **POLITICAL CONTRIBUTIONS**

In compliance with U.S. federal and state election laws, John Deere administers the John Deere Political Action Committee (JDPAC), a voluntary, non-partisan initiative comprised of U.S. employees. JDPAC members voluntarily pool their personal financial contributions to support select federal and state office candidates who understand and support the business interests of our company, customers, employees, and stakeholders. Under federal law and company policy, participation in JDPAC is limited to eligible, salaried U.S. employees.

Except for administrative expenses, JDPAC is funded solely by the voluntary contributions of John Deere employees and is not supported by funds from John Deere itself. The company does not reimburse employees directly or indirectly for political contributions, including contributions to JDPAC.

Oversight of JDPAC's contributions and related activities are governed by its board of directors, comprised of 13 John Deere employees from throughout our various business units. JDPAC does not engage in legislative matters or lobbying activity. Further, JDPAC does not seek to influence any particular vote through contributions.

JDPAC fully discloses all contributions made and received through reports filed with the Federal Election Commission and various state ethics commissions, as required by law. For transparency, John Deere posts an annual report on our website summarizing JDPAC contributions made in the most recent calendar year or election cycle, categorized by state, candidate, and amount. To view the annual report for the 2019–2020 election cycle, please [click here](#).

John Deere complies with federal, state, and local campaign finance laws and regulations governing political contributions and the disclosure of these contributions. Consistent with U.S. federal law, John Deere does not contribute corporate funds to federal candidates, national political party committees, or other federal political committees. For example, even when permitted by applicable law in connection with certain state and local elections, we do not use corporate assets to support or oppose any candidate for political office or ballot measure. The company does, however, reserve the right to make exceptions to this practice so long as any contribution we make is consistent with our public policy agenda, in accordance with our Code of Business Conduct, and previously approved by our Chairman & CEO and Senior Vice President, General Counsel and Public Affairs.

John Deere does not pay for any independent expenditures or electioneering communications, as those terms are defined by applicable law. Moreover, John Deere did not make any political expenditures out of corporate assets in the 2020 or 2021 calendar years. In the interest of transparency for our shareholders and other stakeholders, we publicly disclose and annually update our corporate contributions to associations for advocacy purposes. John Deere belongs to several trade and industry associations and pays regular dues to these groups. We participate in trade associations in part to join other like-minded companies in engaging in public education and advocacy efforts regarding major issues of common concern to our industries.

Our participation in trade associations is subject to management approval and oversight. We publicly disclose and annually update a list of those U.S. trade associations to which John Deere pays dues or makes other contributions of \$50,000 or more, as well as the portions of such dues or payments that are not deductible under Section 162(e)(1) of the Internal Revenue Code. To view the 2021 report for U.S. trade association memberships and expenditures, please [click here](#).

# REPORTING SCOPE AND ISSUANCE

Except where specifically noted otherwise, the reporting period of the John Deere 2021 Sustainability Report covers subject matter and data for Deere & Company's fiscal year 2021 (November 2020–October 2021) and is limited to the operations owned and/or operated by Deere & Company. References to John Deere, our, we, or the Company mean Deere & Company and its subsidiaries, unless the content indicates otherwise. The John Deere Leap Ambitions, referenced throughout this report, were launched on February 18, 2022. This report was published on February 18, 2022.

## FORWARD-LOOKING STATEMENTS

Safe Harbor Statement under the Private Securities Litigation Reform Act of 1995: Statements in this report that relate to future events, expectations, and trends involve factors that are subject to change, and risks and uncertainties that could cause actual results to differ materially. These risks and uncertainties are difficult to predict and often are outside of the control of the company.

When used in this report, the words "may," "could," "anticipate," "target," "plan," "continue," "goal," "commit," "achieve," "project," "intend," "estimate," "believe," "expect," and similar expressions are intended to identify forward-looking statements, although not all forward-looking statements contain such words. Forward-looking statements are subject to certain risks and uncertainties that could cause actual results to differ materially from our historical experience and our present expectations or anticipated results. Forward-looking statements are neither historical facts nor assurances of future performance. Instead, they are based only on the company's current beliefs, expectations, and assumptions regarding the future of its business, strategic objectives, projections, anticipated economic changes and trends, and other conditions. Forward-looking statements in this report may include, but are not limited to, statements regarding the company's operational strategies; equipment designs that optimize performance outcomes for customers; efforts regarding energy, water, and emissions; and the development of mechanisms for tracking sustainability metrics. Important factors that could cause the company's actual results to differ materially from those indicated in the forward-looking statements include, among others, the following: (i) compliance with and changes to global and regional environmental, health, safety, and human rights laws, including emissions and noise regulations, and other ethical business practices; (ii) compliance with and changes to greenhouse gas emissions and other standards related to climate change; (iii) production, design, and technological innovations and difficulties, including capacity and supply constraints and prices; (iv) availability and price of raw materials, components, and whole goods; (v) attracting, developing, engaging, and retaining qualified employees; (vi) weather conditions and natural calamities;

(vii) availability of enabling technologies, including GPS and radio-frequency spectrums; (viii) network security breaches and disruptions; (ix) compliance with privacy and data-protection laws and regulations; (x) global and regional trade laws, regulations, and policies; (xi) governmental banking, monetary, and fiscal policies; (xii) global tax laws; (xiii) demand for food and bioenergy impacting farm commodity pricing and demand for the company's products; (xiv) global political, economic, and social events and uncertainty; (xv) competitors' actions and competitive pressures; (xvi) adapting products to customer preferences around the world; (xvii) infringement of the company's intellectual property; (xviii) economic conditions weakening demand and/or limiting access to funding and higher funding costs; (xix) ability to realize the anticipated benefits of our business strategies including acquisitions, joint ventures, divestitures, or new product or efficiency initiatives; and (xx) impact of the COVID-19 and other pandemics on the company's operations and strategies. The company, except as required by law, undertakes no obligation to update or revise any forward-looking statements, whether as a result of new developments or otherwise.

The forward-looking statements speak only as of the date of this report and undue reliance should not be placed on these statements. Goals are aspirational and not guarantees or promises that all goals will be met. Statistics and metrics relating to ESG matters are estimates and may be based on assumptions or developing standards. This report may contain links and references to other Internet sites. Such links or references are not endorsements of any products or services in such sites, and no information in such site has been endorsed or approved by the company. The inclusion of information in this report should not be construed as a characterization regarding the materiality or financial impact of that information. Further information concerning the company and its businesses, including factors that could materially affect the company's financial results, is included in the company's filings with the SEC (including, but not limited to, the factors discussed in Item 1A, Risk Factors of the company's most recent annual report on Form 10-K, and quarterly reports on Form 10-Q).

# DATA TABLE

Unless otherwise noted, all metrics are determined on a fiscal year 2021 basis.

ENVIRONMENTAL	2021	2020	2019
Energy Consumption (GJ) <sup>1,2</sup>	12,890,000	11,806,000	12,927,000
% Renewable Electricity <sup>1,2</sup>	40.5%	29.2%	23.8%
Scope 1 Emissions (metric tons CO <sub>2</sub> e) <sup>1,2</sup>	403,300	343,500	388,500
Scope 2 (market-based) Emissions (metric tons CO <sub>2</sub> e) <sup>1,2</sup>	407,700	497,000	588,700
Scope 3 Emission (metric tons CO <sub>2</sub> e)	112,453,000	—	—
Category 1	7,336,000	—	—
Category 11	105,117,000	—	—
Water Consumption (megaliters) <sup>3</sup>	23,900	20,246	23,000
% of Waste Recycled <sup>3</sup>	83%	78%	78%
Total Waste (metric tons) <sup>3</sup>	117,200	88,222	108,647
Hazardous Waste (metric tons) <sup>3</sup>	11,600	7,999	13,360
Non-Hazardous Waste (metric tons) <sup>3</sup>	105,600	—	—
# of ISO14001 Manufacturing Sites Certified <sup>4</sup>	35	13	—

<sup>1</sup>Aper Companies, LLC has verified greenhouse gas (GHG) emissions data in accordance with the ISO 14064-3: Greenhouse gases – Part 3: Specification with guidance for the validation and verification of greenhouse gas statements assurance standard and water and waste data in accordance with the ISAE 3000 Revised, Assurance Engagements Other than Audits or Reviews of Historical Financial Information assurance standard.

<sup>2</sup>Data associated with the operation of Unimil is not included in the reported metrics.

<sup>3</sup>Data associated with the operation of Unimil is not included in the reported 2021 metrics. Data associated with the operation of Unimil, PLA Holding Netherlands B.V., Mazzotti S.r.l. and King Agro Europa, S.L., and their related subsidiaries, and the Wirtgen Group entities are not included in the reported 2020 and 2019 metrics.

<sup>4</sup>Manufacturing correlates to definition in our Form 10-K. Wirtgen Group entities are not included in the reported 2020 metrics.

SOCIAL	2021	2020	2019
Number of Employees	75,600	69,600	73,500
% of Part-Time and Student Employees	1.9%	1.4%	—
% of Women in Revenue-Generating Positions	17.3%	—	—
% of Women in STEM-Related Positions	17.6%	—	—
Global Production Employees Covered by Collective Agreements	91.7%	—	—
Turnover Rate — Overall	7.0%	5.0%	4.7%
Turnover Rate — Production	8.6%	4.2%	6.2%
Turnover Rate — Salaried	5.4%	5.8%	3.3%
Training Hours per FTE	19.5	19.8	—
Total Recordable Incident Rate <sup>6</sup>	1.98	1.32	1.65
Lost Time Frequency Rate <sup>6</sup>	0.78	0.32	0.33
Near Miss Frequency Rates <sup>7</sup>	11.96	15.03	—
Fatality Rate <sup>6</sup>	0.001	0.001	—
# of ISO9001 Manufacturing Sites Certified <sup>8</sup>	48	44	—
# of ISO45001 Manufacturing Sites Certified <sup>8</sup>	2	—	—
Charitable Contributions (% of Net Income)	1.5%	1.4%	1.9%
Charitable Contributions (millions USD)	\$42.5	\$36.7	\$37.8
Volunteer Hours	124,332	123,033	215,262

<sup>6</sup>Rate is per 100 employees. Data associated with the operation of Unimil is not included in the reported 2021 metrics. Data associated with the operation of Unimil, PLA Holding Netherlands B.V. and King Agro Europa, S.L., and their related subsidiaries, Mazzotti S.r.l. and the Wirtgen Group entities are not included in the reported 2020 and 2019 metrics.

<sup>7</sup>Rate is per 100 employees. Data associated with the operation of Unimil and the Wirtgen Group entities is not included in the reported 2021 metrics. Data associated with the operation of Unimil, PLA Holding Netherlands B.V. and King Agro Europa, S.L., and their related subsidiaries, Mazzotti S.r.l., and the Wirtgen Group entities are not included in the reported 2020 and 2019 metrics.

<sup>8</sup>Manufacturing correlates to definition in our Form 10-K. Wirtgen Group entities are not included in the reported 2020 metrics.

GOVERNANCE	2021	2020	2019
Total Compliance Training Course Completed	279,147	247,189	236,020
# of Suppliers	4,457	4,533	—
# of Supplier Audits	880	402	—



# DIVERSITY — GENDER

● Male ● Female ● Unidentified

## BOARD OF DIRECTORS<sup>1</sup>

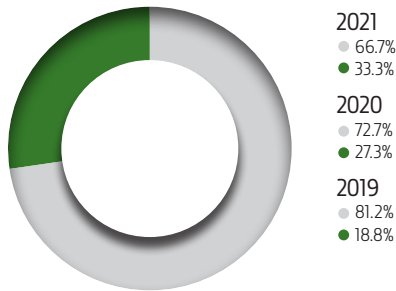

## SENIOR MANAGEMENT

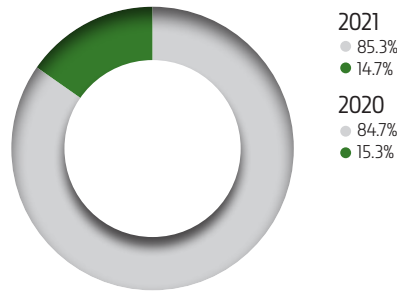

## MANAGEMENT

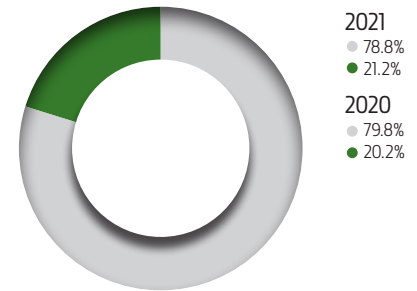

## GENERAL WORKFORCE

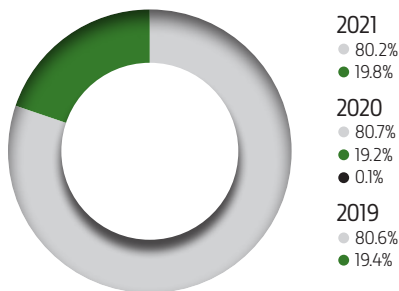

## SALARIED

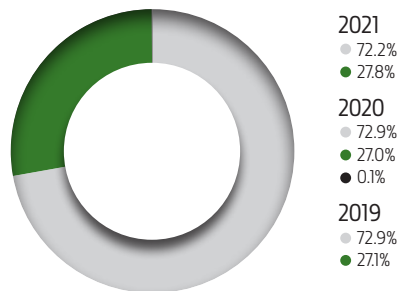

## PRODUCTION

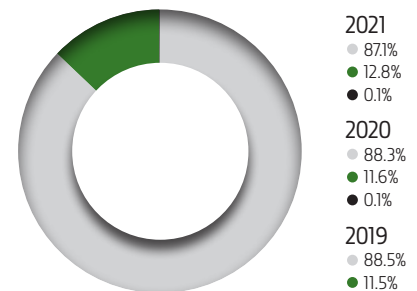

# DIVERSITY — RACE AND ETHNICITY 2021<sup>2</sup>

## AMERICAN INDIAN OR ALASKAN

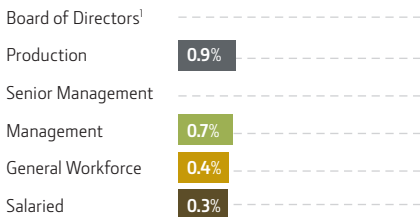

## ASIAN

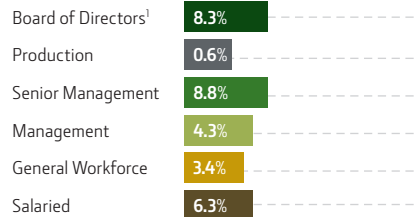

## BLACK OR AFRICAN AMERICAN

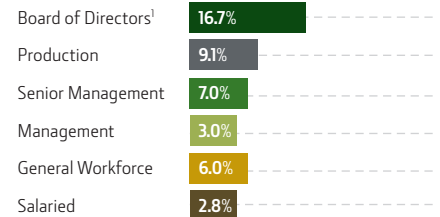

## HAWAIIAN OR PACIFIC ISLANDER

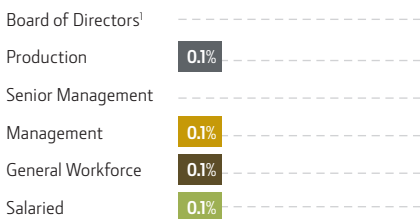

## HISPANIC OR LATINO

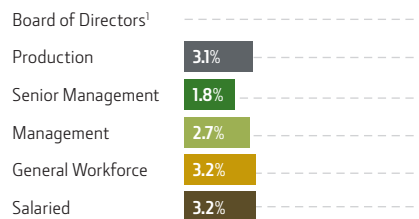

## MULTIPLE RACES

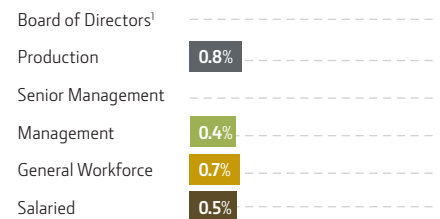

## WHITE

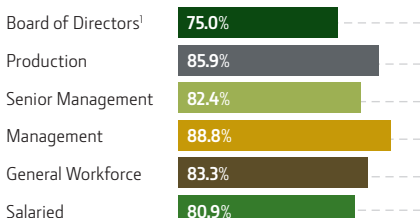

## UNIDENTIFIED

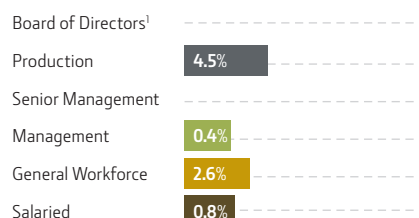

<sup>1</sup> As of November 1, 2021, the first day of Deere's fiscal year 2022, Leanne G. Caret was elected to the Deere & Company Board of Directors. This temporarily raises the number of Deere's Directors to 12. Dipak C. Jain is not standing for re-election at the Deere & Company 2022 Annual Shareholder Meeting on February 23, 2022. Therefore, it is anticipated that the number of Directors will return to 11 following the 2022 Annual Shareholder Meeting. All metrics in this report are calculated on the basis of the 12-member Board of Directors reflected on page 56.

<sup>2</sup> U.S. Employees Only.



**2021 AWARDS**

**AE50 Awards**

*ExactRate™ Liquid Fertilizer System*  
*Harvest Monitor with SmartClean™ System*  
*X9 Combines*  
*CH950 Sugar Cane Harvester*  
*HDR Rigid Cutterbar Drapers*  
*CF Folding Corn Heads*

**America's Best-In-State Employer:  
#38 in Illinois, #5 in Iowa**

*Forbes*

**America's Most JUST Companies:  
#1 for Workers in Commercial Vehicles  
and Machinery Industry**

*JUST 100*

**Best Global Brands**

*Interbrand*

**Top 5 Best Workplaces for Career  
Management – India**

*Great Place to Work*

**World Changing Ideas Award**

*Fast Company*

**World's Most Admired Companies  
#1 in Construction and Farm Machinery**

*Fortune*

**World's Most Ethical Companies**

*Ethisphere Institute*

**X9 Combine Awards**

*iF Design Award*

*Red Dot Award*

